

# VAConnect 7.0

## User's Guide



---

Updated: 8/27/2024

Copyright © 1994-2024 IES, Inc. All rights reserved.

## Table of Contents

1.	<a href="#">Help Topics</a>	2
1.1.	<a href="#">Welcome to VAConnect 7</a>	2
1.2.	<a href="#">Key Features</a>	2-4
1.3.	<a href="#">Program Layout</a>	4-6
1.4.	<a href="#">Upgrade Guide</a>	6-7
1.5.	<a href="#">Release History</a>	7-9
1.6.	<a href="#">Integration with IES Programs</a>	9-11
1.7.	<a href="#">Loads</a>	11-14
1.8.	<a href="#">Base Plate Design</a>	14-19
1.9.	<a href="#">Shear Tab Design</a>	19-22
1.10.	<a href="#">Double Angle Bolted Design</a>	22-25
1.11.	<a href="#">Double Angle Bolted Welded Design</a>	25-27
1.12.	<a href="#">Double Angle Welded Design</a>	27-29
1.13.	<a href="#">Double Angle Welded Bolted Design</a>	29-31
1.14.	<a href="#">Welded Flange Plate Design</a>	31-35
1.15.	<a href="#">Bolted Flange Plate Design</a>	35-37
1.16.	<a href="#">Bolted End Plate Design</a>	37-41
1.17.	<a href="#">Column Splice Design</a>	41-43
1.18.	<a href="#">Beam Over HSS</a>	43-46
1.19.	<a href="#">Wood Bolted Shear Design</a>	46-50
1.20.	<a href="#">Wood Fastener Withdrawal Design</a>	50-51
1.21.	<a href="#">Reporting</a>	51
1.22.	<a href="#">Support Resources</a>	52
1.23.	<a href="#">References</a>	52

## 1 Help Topics

### 1.1 Welcome to VAConnect 7

VAConnect is used to design a variety of steel and wood connections. Each connection type has a dedicated page and [training video](#) in this help file. In addition to being run as a standalone application, VAConnect can be launched from within VisualAnalysis, VisualFoundation, and ConcreteBending (see the [Integration with IES Programs](#) page for details).

#### Getting Started

- Use File | Open Example to see sample projects.
- [Feature List](#)
- [Program Layout](#)
- [Upgrade Guide \(what's new\)](#)
- [FAQ Answers](#) at iesweb.com for business, licensing, installation issues.

#### Help Notation

Menu items appear like this: **File | New**.

Keystrokes or mouse commands appear like this: **Shift+Click**.

#### Disclaimer

VAConnect is a proprietary computer program of Integrated Engineering Software (IES, Inc.) of Bozeman, MT. This product is intended for use by licensed, practicing engineers who are educated in structural engineering, students in this field, and related professionals (e.g. Architects, Building Inspectors, Mechanical Engineers, etc.). Although every effort has been made to ensure the accuracy of this program and its documentation, IES, Inc. does not accept responsibility for any mistake, error, or misrepresentation in, or as a result of, the usage of this program and its documentation. (Though we will make every effort to ensure that problems that we can correct are dealt with promptly.) The results obtained from the use of this program should not be substituted for sound engineering judgment.

#### License and Copy Restrictions

By installing VAConnect on your computer, you become a registered user of the software. The VAConnect program is the copyrighted property of IES, Inc. and is provided for the exclusive use of each licensee. You may copy the program for backup purposes and you may install it on any computer allowed in the license agreement. Distributing the program to coworkers, friends, or duplicating it for other distribution violates the copyright laws of the United States. Future enhancements and technical support depend on your cooperation in this regard. Additional licenses and/or copies of VAConnect may be purchased directly from IES, Inc.

#### IES, Inc.

Integrated Engineering Software, Inc.  
3740 Equestrian Ln Unit 1  
Bozeman, MT 59718

**Sales or Licensing:** 406-586-8988, [sales@iesweb.com](mailto:sales@iesweb.com)

**Technical Support:** [support@iesweb.com](mailto:support@iesweb.com)

### 1.2 Key Features

## Modeling

- VAConnect performs design checks for the following connections:
  - Steel Base Plates Anchored to Concrete
  - Shear Tabs (Single-Plate Connections)
  - Double Angle Bolted Connections
  - Double Angle Bolted/Welded Connections
  - Double Angle Welded Connections
  - Double Angle Welded/Bolted Connections
  - Welded Flange Plate Moment Connections
  - Bolted Flange Plate Moment Connections
  - Bolted End Plate Moment Connections
  - Column Splice Connections
  - Beam Over HSS Connections
  - Wood Bolted Shear Connections
  - Wood Fastener Withdrawal Connections
- VAConnect works as stand-alone products for quick connection checks or design
- VAConnect can be launched from within VisualAnalysis, VisualFoundation, and ConcreteBending for importing:
  - Member shape geometry
  - Names and design criteria settings
  - Design Forces from many LRFD load combinations and load sets

## Loading

- Apply loads in multiple service load cases (e.g. Dead, Live, Seismic, etc.)
- Automatic building code load combinations are available
- Includes IBC, ASCE, and NBC Load Combination
- Create custom load combinations in any project
- Create patterned load cases
- Create Load Sets so one connection can be designed for use in multiple locations

## Reporting

- Report includes graphics of the model
- Reports provide detailed hand style calculations
- Customize reports to include specific detailed calculations or tables
- Print Preview mode while working with reports
- Print to any printer including PDF
- Export reports to .doc or .xlsx

## General

- Dynamic graphical display of the connection to visually validate inputs
- Standard Windows interface for easy navigation
- Unlimited Undo & Redo commands

- Work in any unit system, perform math on input, and use custom unit 'styles'
- Program is self-documenting with tooltips on commands and input parameters
- Numerous preference settings for better defaults
- Free [Training Videos](#) provided for learning efficiency
- Free technical support email with quick responses

## Be a Squeaky Wheel

If you need a new feature, please let us know. We are always looking for ways to improve products in ways that you desire. See [Support Resources](#).

## 1.3 Program Layout

### Explore

The best way to learn VAConnect is to explore the program and try things yourself. Get to know what is available under each button or menu. Also, check out the [tutorial videos](#).

### Screen Layout

The image below introduces the program terminology used in this help file and the training videos. Panels may be resized by dragging their dividers or repositioned by dragging their title bars or right-clicking on the title. Use the "pushpin" icon to collapse panels temporarily to gain more space for working. Hold your mouse over the screen image below for information about each area of the program.

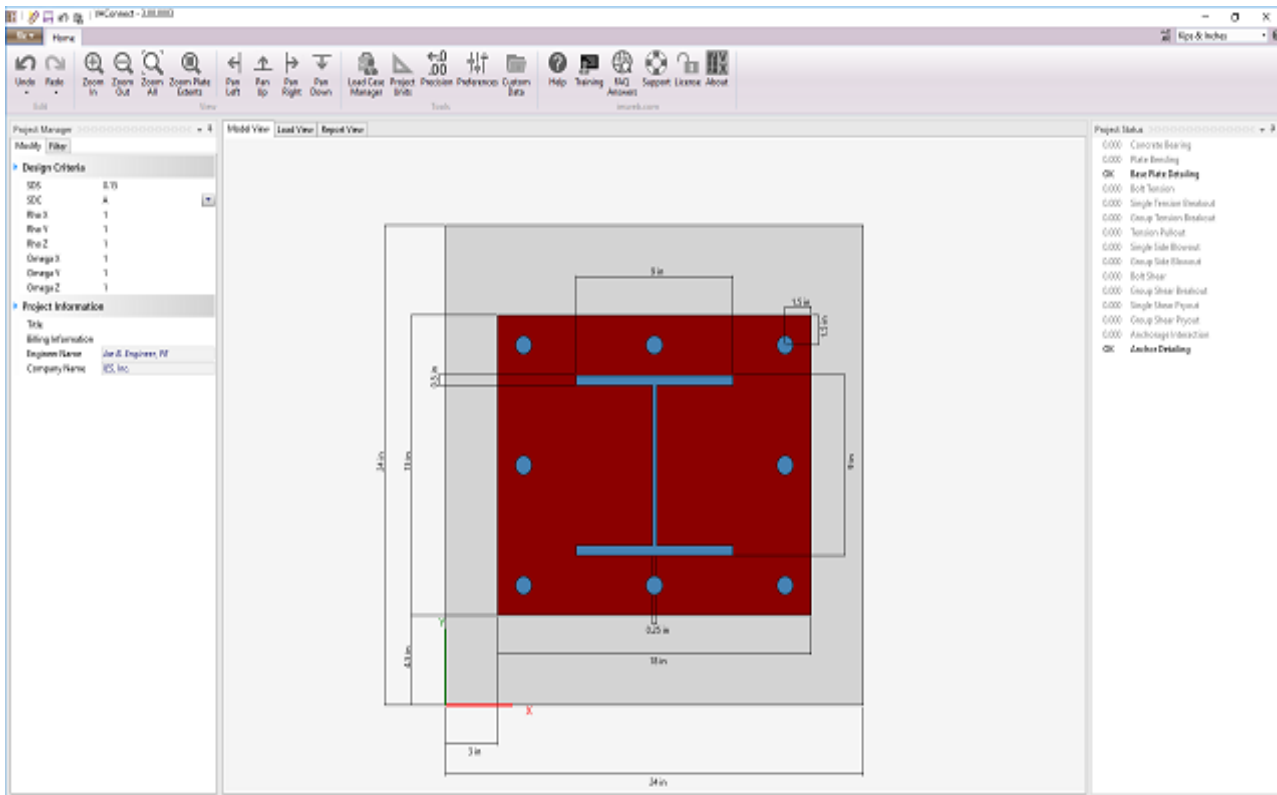

## Main Menu / Toolbar

Each command on the menu or toolbar is accessed with a left mouse click. Helpful descriptions or tool-tips are available by hovering the mouse over the command.

## Project Manager

- Modify Tab: Use this tab to change properties of selected objects, apply loads, or customize reports.
- Filter Tab: Use this tab to control what is shown or hidden in the active view.

## Graphic Views

These views provide a way to view the model, the applied loads, or the reports. Each tab displays different options and will provide different information in the Project Manager. The Model View graphically displays the geometry of the connection. Click on the different components of the model to adjust the geometry and/or material properties for that component. The Load View graphically displays the loads on the connection. Use this view to add service level loads, create load sets, and define the load combinations. The Report View displays the report for the connection which can be modified to be as concise or as comprehensive as needed.

## Project Status

This panel provides a quick summary on which design limit states are passing or failing. Click on the various items to see the calculates for the design checks.

## Units & Precision

VACONNECT can display physical quantities in a variety of unit-systems, including custom unit styles. Select the unit system to use for all the displayed values and adjust the precision (number of decimal places) using the controls in the

upper right corner.

## Data Entry: Physical Quantities

Values may be input in any unit: enter any number or math expression followed by a known unit abbreviation. Length units may be entered in the "ft-in-16ths" notation. Entered values are converted and then redisplayed in the current 'display' units.

## Mouse and Keyboard Commands

### Selection:

- **Click** to select
- **Click** in the 'whitespace' of a view to unselect everything

### Zoom:

- Use the **mouse wheel**, position the mouse over the point from which to zoom in to or out
- **Ctrl+ (plus)** and **Ctrl- (minus)** keys.
- **Ctrl+Home** for zoom all/extents

### Pan:

- Hold the **mouse wheel** down (like a button, not scrolling it) and **drag** the mouse.
- **Shift+Arrow** keys will also pan.

## Middle-Mouse "Button" in Windows

Depending on your system, you may need to go into **Control Panel, Hardware, Mouse**, and set the wheel button to behave like a "middle button click". Some mouse utility programs may override that setting or it may not be set up on some versions of Windows.

## 1.4 Upgrade Guide

### Version 7.0 (May 2024)

#### New Connections

- Double Angle Bolted/Welded (AISC 360-22 & Steel Construction Manual 16th Edition Part 10 & Part12)
- Double Angle Welded (AISC 360-22 & Steel Construction Manual 16th Edition Part 10)
- Double Angle Welded/Bolted (AISC 360-22 & Steel Construction Manual 16th Edition Part 10)

#### New Features

- Two bolt columns implemented for Shear Tab & Double Angle Connections
- Improved bolt tearout limit state for Shear Tab & Double Angle Connections
- Updated methodology for Shear Tab connections containing axial load
- Improved Detailed Reports displayed by controlling limit state
- Upgraded Startup Screen

## Updated Design Specifications

- AISC 360-22 & Steel Construction Manual 16th Edition
- ACI 318-19

## 1.5 Release History

### Overview

#### Versions

- Version 7.0 released May 2024 (current version)
- Version 6.0 released November 2022
- Version 5.0 released August 2020
- Version 4.0 released May 2019
- Version 3.0 released November 2017
- Version 2.0 released January 2014
- Version 1.0 released January 2013

### Version 6

#### Features

##### **\*\* New Connections \*\***

- Double Angle Bolted (AISC 360-16 and Steel Construction Manual Part 10)
- Column Splice (AISC 360-16)
- Beam Over HSS (AISC Design Guide 24)

##### New Features

- Four Bolt Stiffened (4ES) Configuration Added to the Bolted End Plate
- Eight Bolt Stiffened (8ES) Configuration Added to the Bolted End Plate

### Version 5

#### Features

##### **\*\* New Connections \*\***

- Bolted Flange Plate Moment Connection (AISC 360-16 and Steel Construction Manual Part 12)
- Bolted End Plate Moment Connection (AISC Design Guide 4)
- Wood Bolted Shear Connection (NDS 2018)
- Wood Fastener Withdrawal Connection (NDS 2018)

##### Base Plate Connection



- Added an option to analyze the model using a finite element analysis (FEA). The FEA option removes the many limitations of Design Guide One.

## Shear Tab Connection

- The Conventional Configuration is considered when calculating the connection eccentricity.
- The beam can now be coped.
- The exceptions for the shear tab maximum plate thickness check are now considered for the Extended Configuration.

## Version 4

### Features

- Merged Base Plate and Shear Tab into single application
- Significant changes and improvements to user interface
- Added Welded Flange Plate Moment Connection
- Shear Tab Features:
  - a
    - Improved biaxial block shear interaction (per AISC Design Examples Version 15.0)
    - Improved shear, tension, and flexure interactions (per AISC Design Examples Version 15.0)
    - Updated base metal limit state to account for eccentric loading
- Base Plate & Anchorage Features:
  - a
    - Added Case 3 for concrete breakout (per ACI 318-14 Fig. R17.5.2.1b)
- Upgraded to AISC 360-16 and the 15th edition of the AISC Steel Construction Manual
- Updated dynamic project status will more visible limit states
- New web-based Help file that is up to date with the design specifications

## Version 3

### Features

- ACI 318-14 concrete specification
- ASCE 7-16 load combination support
- Threaded rod anchor sizes from 2-4 inches are available
- One inch HAS (headed studs) are available
- Load case manager improvements and updates
- Added material database
- Database for steel shapes may be used
- Preference settings (to speed up new projects)
- Many visual/user-interface improvements
- Improved validation and testing
- Crash prevention improvements

## Version 2

### Features

- New licensing system
- Upgraded to work with VA11

## Version 1

### Features

- Steel Base Plate (with anchorage checks per ACI Appendix D)
- Steel Shear Tab (bolted to beam, welded to column or girder)
- Steel checks per AISC 360-10 (13th Edition)
- Connect checks per ACI 318-08

## 1.6 Integration with IES Programs

VAConnect may be run as a standalone program or launched from within VisualAnalysis, VisualFoundation, or ConcreteBending. Launching from these IES products allows loading demands and available connection information to be exported from the model to VAConnect. The following table shows the connection types that are supported by the various IES programs.

### Connection VisualAnalysis VisualFoundation ConcreteBending

Base Plate	<b>Yes</b>	<b>Yes</b>	<b>Yes</b>
Shear Tab	<b>Yes</b>	No	No
Double Angle Bolted	<b>Yes</b>	No	No
Double Angle Bolted Welded	<b>Yes</b>	No	No
Double Angle Welded	<b>Yes</b>	No	No
Double Angle Welded Bolted	<b>Yes</b>	No	No
Welded Flange Plate	<b>Yes</b>	No	No

## Connection VisualAnalysis VisualFoundation ConcreteBending

Bolted Flange Plate	<b>Yes</b>	No	No
Bolted End Plate	<b>Yes</b>	No	No
Column Splice	No	No	No
Beam Over HSS	No	No	No
Wood Bolted Shear	No	No	No
Wood Fastener Withdrawal	No	No	No

## Integration with VisualAnalysis

IES [VisualAnalysis](#) is a 3D integrated analysis and design tool used to model a variety of structures using an assortment of materials. VisualAnalysis determines the flow of forces through a structure for each load combination and can perform design checks for the structural members based on a number of different design specifications. Using the steps below, VisualAnalysis can directly export member and load data to VAConnect to expedite the connection design and eliminate the bookkeeping involved with moving information between the computer programs.

1. Create a structural model in VisualAnalysis, apply load, and select the appropriate load combinations.
2. Switch to the **Results View** to validate/review the analysis results.
3. Switch to the **Design View** tab in the graphics view and ensure that the Steel Connections filter is set to "Shown" in the **Project Manager | Design Filter** tab to display the connections graphically.
4. Create/Modify the desired connection groups using the buttons in the connections section of the **Design Ribbon**.
5. Select a connection and click the **Design in VAConnect** button to launch VAConnect and automatically import the member, load combination, and load set data for the connection.
6. Modify the connection in VAConnect until all of the design checks pass.
7. Save the VAConnect project file if desired to open it later in the stand-alone mode.
8. Exit VAConnect, the design report is automatically sent back to VisualAnalysis and the connection Design Status is change from 'Not Performed' to either 'Checks Passed' or 'Checks Failed'.

Note: the import from VisualAnalysis feature is unidirectional as VisualAnalysis does not store any input data or changes made to connection project files. Editing the model or the loads in VisualAnalysis will reset the Design Status of the connections to 'Not Performed' and they will need to be redesigned.

## Integration with VisualFoundation

IES [VisualFoundation](#) is used to analyze and design a wide variety of concrete foundation systems, including complex mat footings, pile caps, grade beam systems, and combined footings. VisualFoundation can export pier-loads to VAConnect for a steel-column base plate design. After defining all of the loads, select the pier(s) in the Model & Loads

view, and click the **Export to VACONNECT** button in the **Foundation Ribbon**.

## Integration with ConcreteBending

IES [ConcreteBending](#) is used to analyze and design a wide variety of concrete elements in flexure, including elevated slabs, beams, tank walls, and foundation walls. ConcreteBending can export point loads to VACONNECT for a steel-column base plate design. After defining all of the loads, select the load point(s) in the Model & Loads view, and click the **Export to VACONNECT** button in the **Boundary and Support Ribbon**.

## 1.7 Loads

### Load Cases and Combination Types

The load case manager is used to view and manage all load cases and load combinations in the project. Under the Service Cases tab, new service cases can be created and existing service cases can be modified or delete. Under the Load Combinations tab, the load combinations from several different building codes can be added or custom Factored combinations can be created.

Case Type	Description
Service Case	A container for holding physical loads grouped by load source. These load cases are not used directly for the design checks.
Building Code Combination	Automatic load combinations are generated based on defined building code equations. While building code combinations cannot be modified, the combinations from various codes can be included or excluded from the analysis. Also, any automatic load combination can be converted to a custom Factored Combination.
Factored Combination	Custom combinations of service cases with load factors that can be used for design checks.

### Service Cases & Load Sources

Loads on a structure can come from a variety of sources such as the self-weight of the structure (Dead Load), external loads applied to the structure (Live Load, Snow Load, Wind Load, etc.), loads from inertia forces due to dynamic motion (Seismic Loads), and loads that are self-straining (Thermal Loads, Creep Loads, etc.). A variety of load sources are available in VACONNECT (see the table below) which are based on the ASCE 7 and IBC design specifications. Service loads are the actual imparted loads on the structure to be used in the Load Combinations for the design checks. VACONNECT automatically generates the service cases in the table below based on the various load sources. While load sources cannot be modified in VACONNECT, custom Service Load Cases can be manually added in the Service Cases tab of the Load Case Manager. For example, a "Creep" Service Load Case could be added based on the Self Straining Load Source. All loads are added at the service load level in VACONNECT.

Load Source	Service Load Case	Explanation
Dead	D	The self-weight of the structure and permanent fixtures on or in the structure.
Dead (Ice)	Di	The weight of ice on the structure.
Live	L	Loads due to moveable equipment or occupancy. Caution: Live loads are reduced by 50% in some IBC load combinations, use Lpa source for loads > 100 psf.

Load Source	Service Load Case	Explanation
Live (Public Assembly)	Lpa(> 100psf)	Garage loads, Public Assembly areas, or loads greater than 100psf. They have also been called "Exception" loads, because they appear in a separate clause in some building codes.
Roof Live	Lr	Roof live loads.
Rain	R	Rain load on an undeflected roof (excludes contributions from ponding).
Snow	S	Snow loads.
Seismic Loads (directional)	E+X, E-X, E+Y,E-Y, E+Z, E-Z	Earthquake or Seismic loads. E+X is for seismic loads in the positive global X-direction, E-X is in for the negative global X-direction, and similarly for the Y-direction and Z-direction.
Earth Pressure	H	Load due to lateral earth pressure, ground water pressure, or pressure of bulk materials
Fluids	F	Fluid load such as water in a storage tank.
Flood	Fa	Loads that result from water exceeding the local ground elevation. Flood load come from hydrostatic and hydrodynamic pressures such as water flowing over a bridge or waves passing through a building.
Self Straining	T	Loads from thermal expansion, creep, support settlement, etc.
Wind loads (directional)	W+X, W-X, W+Y, W-Y, W+Z, W-Z	Wind pressure loads. W+X is for wind loads in the positive global X-direction, W-X is for wind loads in the negative global X-direction and similarly for the Y-direction and Z-direction. Skewed wind load directions are also available (W+X+Y, W+X-Y, W-X+Y, etc.).
Wind on Ice	Wi+X, Wi-X, Wi+Y, Wi-Y, Wi+Z, Wi-Z,	Wind on Ice. The presence of ice can increase the surface-area of members and therefore the wind forces.
Other loads	Other	User-defined source available for special loads that need to be factored independently of other sources. These loads are not used in Building Code Combinations but can be used in Custom Factored Combinations.

## Building Code Combinations

Building code combinations from a variety of building codes are built-in to VAConnect. The codes that are selected in the Load Case Manager are automatically maintained as loads are added or removed to the service cases. The building code combinations implemented in VAConnect do not necessarily represent all possible load combinations or variations present in a particular building code (for example, in the implementation of ASCE 7-10 load combinations, the major equations are implemented, but exceptions clauses of section 2.4 dealing with H, F, Fa are not implemented directly).

# VAConnect 7 User's Guide

When one of the building code combinations is selected, VAConnect will use the current service load cases and generate the necessary combinations prescribed for that code. Note that any custom equation or factored combinations that are created manually will remain unaffected. When VAConnect generates building code combinations, it will generate combinations including the effects of wind and seismic in various directions, including (+/-X, +/-Y, +/-Z). Only load cases that actually contain loads are included in the combinations. The Load Case Manager displays the 'effective' combination of the equation which may be different than the equation in the building code.

## Custom Load Combinations

Use the Create Factored Combination button located in the **Load Case Manager** to create any custom combination needed. Custom factored load combinations can be imported from the clipboard using the **Import From Clipboard** button in the Load Combinations tab in the **Load Case Manager**. Text must be tab delimited and copied to the clipboard in the following format:

```
{ComboName} {Factor} {ServiceCaseName} {Factor} {ServiceCaseName2} ...
```

For example:

ComboName	1.2	D	1.6	L	0.5	Lr
MyCombo	0.9	D	1.3	W		

## Patterned Load Cases

Service cases may be given a pattern ID number allowing for various loading patterns to be modeled (such as loads on the odd/even spans). Each patterned service load case is combined independently in building code load combinations from other patterned load cases. For example, when dead load is applied and odd-span live loads are in a "Pattern 1" service case and even-span live loads are in a "Pattern 2" service case, the building code combination will generate the following combinations:

1.2D + 1.6L(1) (#1)  
1.2D + 1.6L(2) (#2)

Any loads in an non-patterned load case (i.e. the dead loads for the example case above) are included in all of the load combinations. All of the built-in service cases have a default load patterns of 0 that cannot be changed. Therefore, new service cases must be created to define load patterns.

## Load Sets

It is common for the same connection to be used at multiple locations throughout a structure and experience numerous loading conditions. The Load Sets feature in VAConnect allows a single connection to be designed with multiple sets of loads. For example, consider a structure with two W16x36 beams that use identical shear tab connections. The beams carry service level loads that produce the service level shear forces in the connection shown in the table below.

<b>Service Load Case</b>	<b>Load Set 1 = Beam 1 Shear Force (kips)</b>	<b>Load Set 2 = Beam 2 Shear Force (kips)</b>
Dead (D)	10	9
Live (L)	20	24
Snow (S)	20	16

It is not immediately apparent which set of loads (the shear on Beam 1 or Beam 2) will control the design of the

connection. Based on ASCE 7, one of the following load combinations will control the design of the connection. The table below shows the six load combinations (three from each load set) that are used to design the connection. In VAConnect, the connection is designed for all six load combinations and can therefore be used for both beams.

- 1) 1.4D
- 2) 1.2D + 1.6L + 0.5S
- 3) 1.2D + 0.5L + 1.6S

Load Set	Load Combination	Connection Design Loads (kips)
Beam 1	1.4D	14.0
Beam 1	1.2D + 1.6L + 0.5S	54.0
Beam 1	1.2D + 0.5L + 1.6S	54.0
Beam 2	1.4D	12.6
Beam 2	1.2D + 1.6L + 0.5S	57.2
Beam 2	1.2D + 0.5L + 1.6S	48.8

## 1.8 Base Plate Design

The base plate connection consists of a steel plate that is welded to the base of a column and anchored to a concrete slab or pedestal. The connection resists the reactions from the column including the axial force, shear forces, and moments.

### Design Considerations

- Steel base plates and anchorage subjected to applied axial forces and overturning moments are analyzed according to AISC Design Guide 1 (DG1) or with a finite element analysis.
- Base plate design checks for flexure are performed per AISC 360-22.
- Concrete bearing design checks are performed per ACI 318-19.
- Anchorage design checks for shear and tensions demands are performed per ACI 318-19 Chapter 17. Anchorage design is not available when the connection is analyzed using finite element analysis because ACI design provisions assume a rigid plate connects the anchors.
- Anchorage breakout areas for both shear and tension can be graphically displayed.
- Anchorage breakout checks can be suppressed when reinforcing is provided to prevent breakout.

### Limit States

VAConnect checks the following limit states for Base Plates (refer to the program's detailed reports for code references):

- Concrete bearing
- Steel plate bending
- Base plate detailing

- Bolt spacing
- Bolt minimum edge distances for the steel plate
- Bolt tension
- Single anchor tension breakout
- Anchor group tension breakout
- Tension pullout
- Single anchor side blowout
- Anchor group side blowout
- Bolt shear
- Anchor group shear breakout (cases 1, 2 & 3)
- Single anchor shear pryout
- Anchor group shear pryout
- Anchorage tension and shear interaction
- Anchorage detailing
  - Anchor spacing
  - Anchor side cover

## Limitations

- Permitted shapes: I-Beams, HSS (rectangular tubes), Pipes, and Rectangular or Round Columns
- Base plate is assumed to be perpendicular to the member's local axis
- Limited to a single member framing into the plate (i.e. braces may connect to the base plate)
- If analyzing with the DG1 method, all of the limitations of DG1 apply to the base plate program, notably:
  - DG1 does not support biaxial bending in the plate
  - DG1 does not support the case of an applied axial tension and applied moment
  - Only one row of anchors is allowed around the four sides of the base plate
  - DG1 simplifies the base plate analysis into essentially a one-dimensional problem (engineering judgment is required to determine when this simplifying assumption is appropriate)
  - Please refer to DG1 for further information
- The column-to-base-plate weld is not checked
- Only bending design checks are made on the plate (bolt bearing, block shear, and other steel connection checks are not considered)
- The anchorage design checks do not support post-installed anchors
- The overstrength option (ACI 318-19 Section 17.10.3.4.3d) is used for seismic design for both shear and tension. Also, the tension capacity is reduced per 17.10.5.4. Therefore, the user must to define omega in the project criteria to considering seismic effects.
- The provisions of ACI 318-19 Section 17.7.2.1 (c) and (d), concerning shear parallel to an edge and shear at a corner, are not checked (these checks can be manually performed, by applying the correct load towards the edge)
- Torsional column reactions are not considered in the analysis or design
- Biaxial shear anchorage interaction is not supported

## Finite Element Analysis

As an alternative to DG1, finite element analysis can be used to find the critical plate bending moment and concrete bearing pressure. Finite element analysis removes the loading and one-way bending limitations of DG1 (see above).



Finite element analysis and DG1 are built on entirely different assumptions about the base plate connection's behavior (for example, DG1 assumes the plate is rigid). Results from the two analysis methods will often differ significantly.

The base plate is modeled using plate elements. Very stiff plate elements are used in the region of the plate under the column. One-way elastic springs model the concrete and anchorage. The user must define the stiffness of the concrete support and the anchor bolts. The mesh element size must be adjusted until the bearing and bending unity values converge. A significant amount of engineering judgment is required for a successful analysis. Information on the element formulation used and a discussion of mesh refinement can be found in the [VisualAnalysis Help File](#).

The bending moment used for plate design is calculated by taking the extreme principal stress times the plate's section modulus. The bending demand can spike near the corners of wide-flange and rectangular columns. Users are given the option of ignoring these spikes by disregarding the demands within a specified distance from these corners. To view the model and results in detail, export the FEA model to VisualAnalysis.

Anchorage design checks are not performed when FEA is used since ACI's assumption of a rigid plate may not be satisfied.

## Shear Breakout Groups and Load Distribution

Various load distributions must be considered when designing anchors for shear demands. This process is described by Figure R17.7.2.1b of ACI 318-19 chapter 17. The figure describes three cases that must be considered when designing for shear breakout. The logic behind the commentary cases, which involves only two anchors, leads to many possible breakout cases when the group has multiple anchors. VAConnect's anchorage design checks take the following approach:

- A breakout group is considered for each anchor in the connection. The shear force carried by each group is taken as the total shear demand times the ratio of the anchors in the breakout group to the total number of anchors in the connection (see the figure below). The shear limit states of bolt shear and pryout are checked for each breakout group. VAConnect can graphically display the breakout group for each anchor.

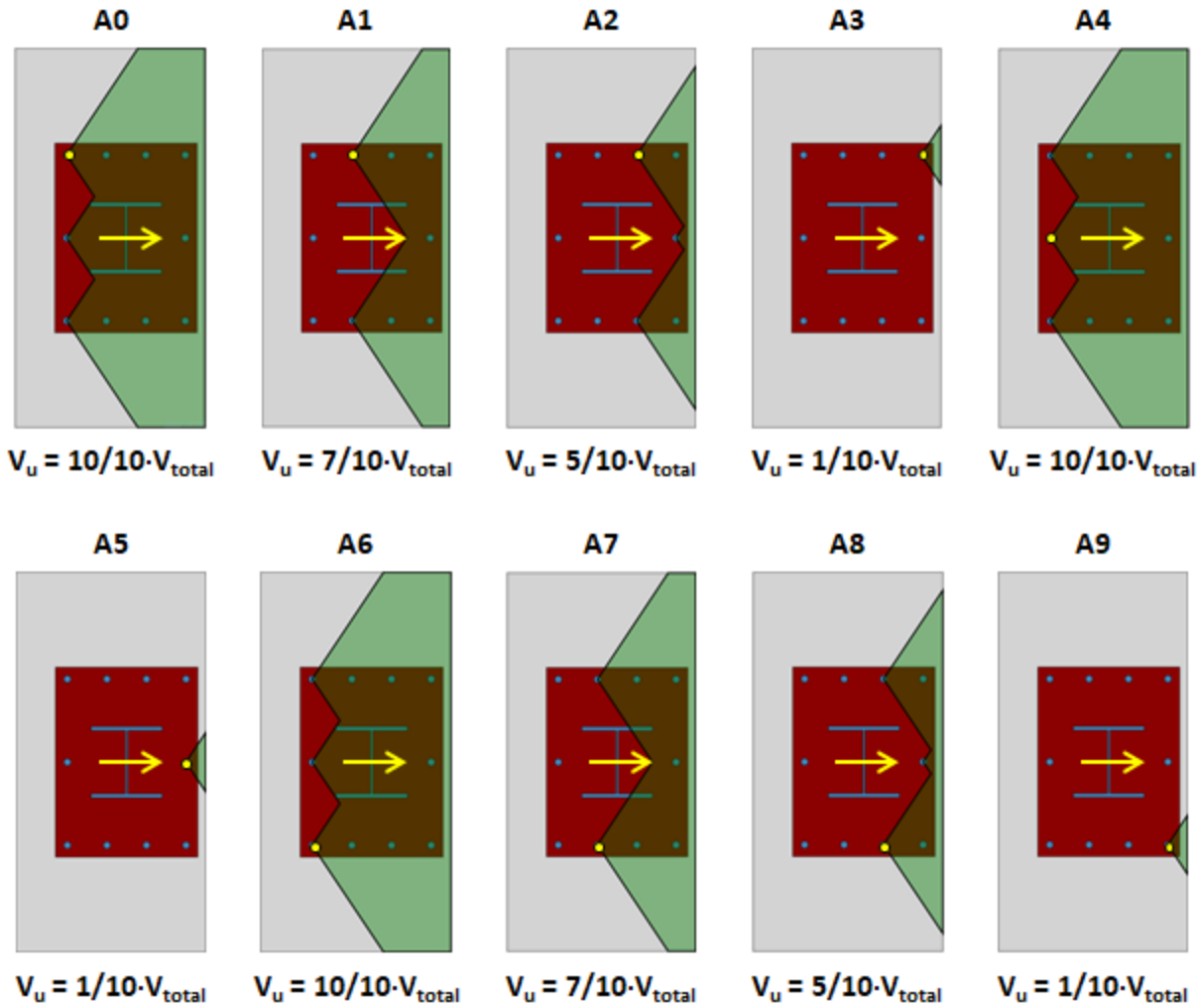

### Concrete Breakout for Anchor Group – Case 1

- If the anchors are welded to the steel plate (as specified by the user), only the breakout group starting from the back row of anchors (Case 2) is considered as discussed in ACI 318-19 Section 17.7.2.1.

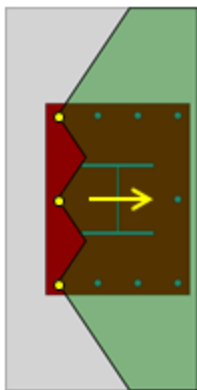

$$V_u = V_{total}$$

### Concrete Breakout for Anchor Group – Case 2

- If the overall anchor spacing ( $s$ ) is less than the edge distance to the near-edge anchors ( $c_{a1,1}$ ) as shown in the following figure, then the failure surfaces may merge and Case 3 is conservatively used for the strength of the breakout group (see ACI 318-19 Section 17.7.2.1). It should be noted that Case 3 is also applicable if the base plate holes are such that front row of anchors take the majority of the load before the rest of the anchors are engaged (see Example 8 of ACI 355.3R-11 page 76 for further discussion of when this more severe load distribution may exist). VAConnect, however, does not considered Case 3 based on the bolt hole condition.

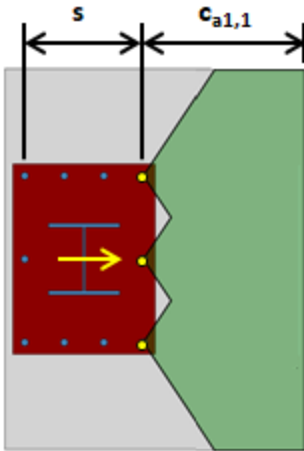

**Concrete Breakout for Anchor Group – Case 3**

## Bolt Shear and Load Distribution

When the anchors near the free edge start to form a failure cone due to concrete breakout the load will redistribute to the stiffer rear anchors as explained in ACI 318-19 R17.7.2.1. Therefore, VAConnect only uses the anchors farthest from the edge (on the perimeter of the breakout group) for the bolt shear limit state (see Example 10 of ACI 355.3R-11 particularly page 92). The figure below shows the demand and the number of bolts that resist shear for the breakout group associated with each anchor. The bolt shear unity value ( $V_u/\phi V_n$ ) is conservatively taken as the maximum unity value of all the cases for bolt shear regardless of which breakout case controls.

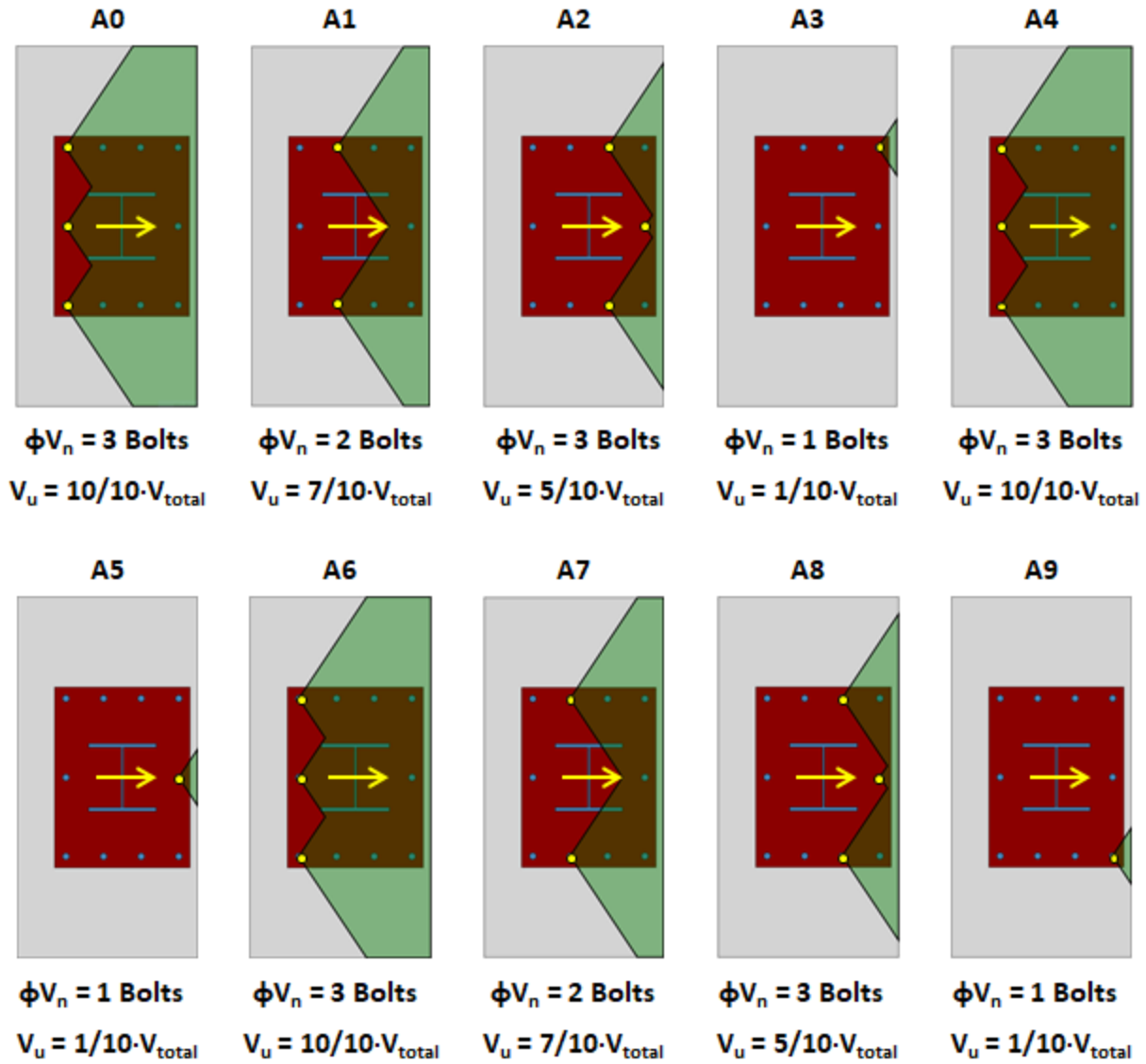

***Bolts Engage for the Bolt Shear Limit State for each Shear Anchor Breakout Group***

## Anchorage Interaction

The anchorage design checks consider the interaction of tension and shear forces per ACI 318-19 Section 17.8. The design checks, however, do not consider the interaction of biaxial shear forces in two perpendicular directions. In the case of a connection subjected to shear forces in the X and Y directions ( $V_x$  and  $V_y$ ) and a tension force ( $T$ ), the interaction check will consider  $V_x$  combined with  $T$  and  $V_y$  combined with  $T$ , separately. The combination of  $V_x$ ,  $V_y$ , and  $T$  is not considered by the program because there is no guidance provided by the ACI 318-19 specification. Therefore, this particular design check is left to the discretion of the user.

## 1.9 Shear Tab Design

Shear Tab connections (also know as Single-Plate connections) are used to connect steel beams to column or girders. VAConnect is capable of designing these connections to support coped beams and to resist both shear and axial loads.

## Design Considerations

### Conventional & Extended Configuration

Shear Tab connections are checked per the AISC Steel Construction Manual Part 10 (16th Edition) and AISC 360-22 design specifications. If the dimensional limitations outlined in AISC Manual Part 10 are met (page 10-49), VAConnect automatically designs the connection using the procedure for the conventional configuration. Otherwise, the procedure for the extended configuration is used for design. For both connection configurations, the Instantaneous Center of Rotation method is used to determine the eccentric bolt group capacity (shear, bearing, and tearout) at the shear tab and web of the beam. The Instantaneous Center of Rotation method is also used to determine the capacity of the eccentrically loaded welds groups and base metal. Both the connection configuration and the “C” coefficients for eccentrically loaded bolt groups and eccentrically loaded weld groups are included in the detailed reports.

### Combined Axial Force and Eccentric Shear Force

VAConnect allows shear tab connections to be designed for combined eccentric shear force (force in-plane and parallel to the bolt line) and axial force (force in-plane and perpendicular to the bolt line) according to the AISC Steel Construction Manual Part 12 (16th Edition). Example II.A-19B of the AISC Design Examples Version 16.0 provides a detailed example of an extended shear tab connection subject to axial and shear loading. While previous version of VAConnect relied on engineering judgment to account for the axial force, VAConnect has been revised to closely follow the Part 12 of the AISC Steel Construction Manual (16th Edition) and the aforementioned AISC design example. Specifically, the interaction of the shear, axial, and flexural loads are considered for both the yielding/buckling limit state and for the rupture limit state. Also, the interaction for biaxial block shear is accounted for according to the example. The program’s detailed reports clearly document how the various limit states have been checked.

Note: When the connection has a conventional configuration, the eccentricity is not reduced for load combinations where shear and axial force is present as discussed in the Design Considerations for Single-Plate Connections Subject to Shear and Axial Force in Part 12 of the AISC Steel Construction Manual (16th Edition). See also Example II.A-17B of the AISC Design Examples Version 16.0.

### Coped Beams

Beams coped at one or both flanges are checked per the AISC Steel Construction Manual Part 9 (16th Edition) and AISC 360-22 design specifications. The 16th Edition of the AISC Steel Construction Manual does not explicitly address how to design coped beams for combined shear and axial loading. Therefore, VAConnect uses the same methodology as the shear tab in Part 12 of the AISC Steel Construction Manual (16th Edition) and in Example II.A-19B of the AISC Design Examples Version 16.0 to account for the interaction of the shear, axial, and flexural loads for both the yielding/buckling and the rupture cases of the coped beam. Furthermore, the interaction for biaxial block shear on the coped beam is accounted for according to the aforementioned example.

### Limit States

VAConnect checks the following limit states for Shear Tabs (refer to the program’s detailed reports for specific code references):

- **Welds & Bolts**
  - Fillet Weld
  - Base Metal - Tab
  - Base Metal - Support
  - Bolt Group Capacity (Shear, Bearing, & Tearout) - Tab
  - Bolt Group Capacity (Shear, Bearing, & Tearout) - Beam Web
  - Block Shear - Tab

- Block Shear - Beam Web
- **Shear Tab**
  - Shear Yield
  - Tension Yield
  - Compression Buckling
  - Flexural Yielding/Buckling
  - Yielding/Buckling Interaction
  - Shear Rupture
  - Tension Rupture
  - Flexural Rupture
  - Rupture Interaction
- **Beam**
  - Shear Yield
  - Tension Yield
  - Compression Buckling
  - Flexural Yielding/Buckling
  - Yielding/Buckling Interaction
  - Shear Rupture
  - Tension Rupture
  - Flexural Rupture
  - Rupture Interaction
- **Connection Detailing**
  - Shear tab maximum plate height
  - Maximum plate thickness
  - Fillet weld maximum and minimum size
  - Number of fillet weld lines
  - Welds are adequate to developed Shear Tab strength
  - Maximum and minimum bolt spacing
  - Maximum and minimum bolt edge distances

## Limitations

- Permitted beam shapes: I-Beams and Channels
- Permitted supporting member shapes: I-Beams, Channels, HSS, Pipe, Rectangle, or Round. The support member is only limited when importing from VisualAnalysis.
- The support element is only considered as far as it affects the weld design (e.g. base metal check, minimum and maximum fillet weld sizes)
- Weld base metal checks assume that there is not a connection on the opposite side of the support
- Beam is nearly perpendicular to the column or girder
- A single member framing into a support column or girder
- Only a single or double vertical row of bolts is allowed
- Single coped channels are not supported
- Only standard bolt holes are supported
- Only forces in the plane of the connection (shear and axial) can be checked
- When an unrecognized beam is imported from VisualAnalysis, the beam's T dimension is assumed to be the

depth minus twice the flange thickness (i.e. the fillets are neglected)

## Block Shear

The figure below shows the possible block shear failure methods that VACONNECT checks for the shear tab. In addition to checking each case (a through d) independently, the interaction for block shear failure from combined shear and tension is considered. While combined block shear only needs to be checked for case a and case b in the figure below, VACONNECT conservatively uses the lowest capacity from case b through case d for tension to combine with case a for shear. VACONNECT checks the appropriate block shear failure methods and block shear interaction as needed for the web according to the beam's coped condition.

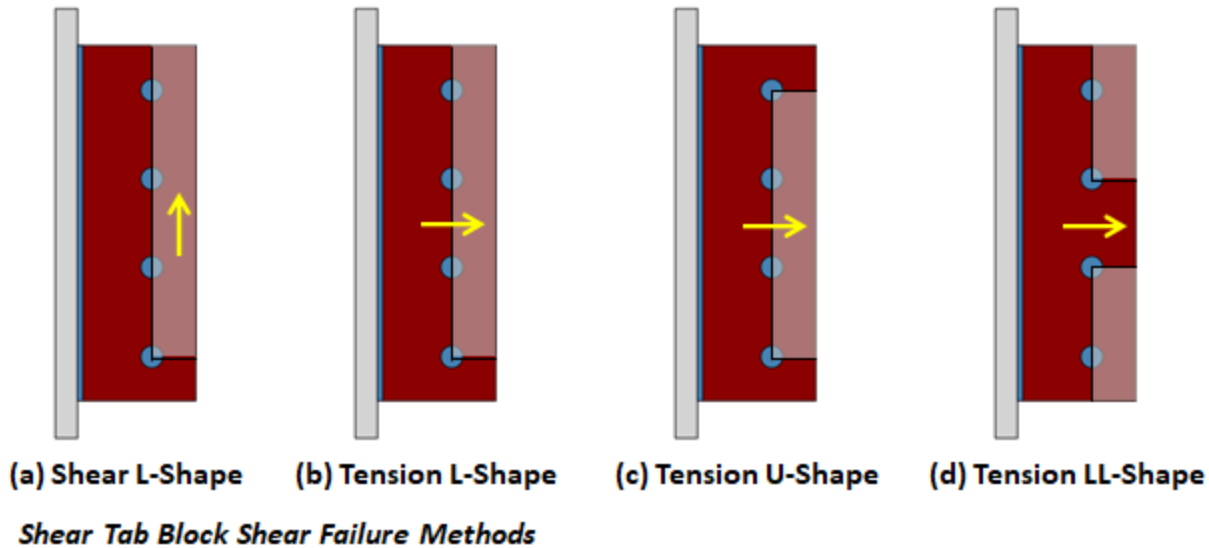

## 1.10 Double Angle Bolted Design

Double Angle Bolted connections are used to connect steel beams to column or girders. VACONNECT is capable of designing these connections to support coped beams and to resist both shear and axial loads.

### Design Considerations

#### Connection Eccentricity

Double Angle Bolted connections are checked per the AISC Steel Construction Manual Part 10 (16th Edition) and AISC 360-22 design specifications. In accordance with AISC part 10, the eccentricity on the supported side of the double-angle connection (i.e. the beam side) is neglected when a single vertical row of bolts through the beam does not exceed a distance of 3 inches from the face of the support. When this condition is not met, VACONNECT accounts for eccentricity using the Instantaneous Center of Rotation method to determine the eccentric bolt group capacity (shear, bearing, and tearout) at the beam side of the double angle and at the web of the beam. The "C" coefficients for eccentrically loaded bolt groups are included in the detailed reports.

VACONNECT assumes that the pin (which allows for rotational ductility) occurs at the face of the support. Therefore, eccentricity at the faying surface of the double angles and the support is not considered. While VACONNECT limits the maximum thickness of the double angle connection to 5/8 inches to allow for flexibility in the connection, the workable gage of the bolts to the support is not specifically checked in the program.

#### Combined Forces

VACONNECT allows double angle bolted connections to be designed for combined axial and shear forces neglecting eccentricity according to the AISC Steel Construction Manual Part 12 (16th Edition) and closely following Example II.A-1B of the AISC Design Examples Version 16.0. Bolt shear and tension interaction (including prying) and biaxial block shear interaction are both accounted for according to the example.

VACONNECT also allows double angle bolted connections to be designed for combined eccentric shear force (force in-plane and parallel to the bolt line in the beam's web) and axial force (force in-plane and perpendicular to the bolt line in the beam's web). Since the AISC Design Examples Version 16.0 does not explicitly address this combined force condition for all bolted double angles, VACONNECT uses the methods outlined in Example II.A-19B (Extended single-plate connection subject to axial and shear loading) to design the legs of the angles that are connected to the beam for combined eccentric shear and axial force. Specifically, the interaction of the shear, axial, and flexural loads are considered for both the yielding/buckling limit state and for the rupture limit state. The program's detailed reports clearly document how the various limit states are checked.

## Coped Beams

Beams coped at one or both flanges are checked per the AISC Steel Construction Manual Part 9 (16th Edition) and AISC 360-22 design specifications. The 16th Edition of the AISC Steel Construction Manual does not explicitly address how to design coped beams for combined shear and axial loading. Therefore, VACONNECT uses the same methodology as the shear tab in Part 12 of the AISC Steel Construction Manual (16th Edition) and in Example II.A-19B of the AISC Design Examples Version 16.0 to account for the interaction of the shear, axial, and flexural loads for both the yielding/buckling and the rupture cases of the coped beam. Furthermore, the interaction for biaxial block shear on the coped beam is accounted for according to the aforementioned example.

## Limit States

VACONNECT checks the following limit states for Double Angle Bolted Connections (refer to the program's detailed reports for specific code references):

- **Bolts**

- Bolt Tension w/ Shear & Prying - Support
- Bolt Group Capacity (Shear, Bearing, & Tearout) - 2L @ Beam
- Bolt Group Capacity (Shear, Bearing, & Tearout) - Beam Web
- Bolt Group Capacity (Shear, Bearing, & Tearout) - 2L @ Support
- Bolt Group Capacity (Shear, Bearing, & Tearout) - Support
- Block Shear - 2L @ Beam
- Block Shear - Beam Web
- Block Shear - 2L @ Support

- **Double Angle**

- Shear Yield - 2L @ Support
- Shear Yield - 2L @ Beam
- Tension Yield - 2L @ Beam
- Compression Buckling - 2L @ Beam
- Flexural Yielding/Buckling - 2L @ Beam
- Yielding/Buckling Interaction - 2L @ Beam
- Shear Rupture - 2L @ Support
- Shear Rupture - 2L @ Beam
- Tension Rupture - 2L @ Beam
- Flexural Rupture - 2L @ Beam



- Rupture Interaction - 2L @ Beam
- **Beam**
  - Shear Yield
  - Tension Yield
  - Compression Buckling
  - Flexural Yielding/Buckling
  - Yielding/Buckling Interaction
  - Shear Rupture
  - Tension Rupture
  - Flexural Rupture
  - Rupture Interaction
- **Connection Detailing**
  - Double angle maximum length
  - Maximum angle thickness
  - Maximum and minimum bolt spacing
  - Maximum and minimum bolt edge distances

## Limitations

- Permitted beam shapes: I-Beams and Channels
- Permitted supporting member shapes: I-Beams, Channels, HSS, Pipe, Rectangle, or Round. The support member is only limited when importing from VisualAnalysis.
- The support element is only considered as far as it affects the bolt design (e.g. bolt shear, bearing, and tearout at the support)
- The eccentricity at the faying surface of the double angles and the support is not considered as the pin which allows for rotational ductility is assumed to occur at the face of the support
- Beam is nearly perpendicular to the column or girder
- A single member framing into a support column or girder
- Only a single or double vertical row of bolts is allowed at the beam
- Only a single vertical row of bolts is allowed in each angle at the support
- Single coped channels are not supported
- Only standard bolt holes are supported
- Only forces in the plane of the connection (shear and axial) can be checked
- When an unrecognized beam is imported from VisualAnalysis, the beam's T dimension is assumed to be the depth minus twice the flange thickness (i.e. the fillets are neglected)

## Block Shear

The figure below shows the possible block shear failure methods that VAConnect checks for the double angles. In addition to checking each case (a through d) independently, the interaction for block shear failure from combined shear and tension is considered. While combined block shear only needs to be checked for case a and case b in the figure below, VAConnect conservatively uses the lowest capacity from case b through case d for tension to combine with case a for shear. VAConnect checks the appropriate block shear failure methods and block shear interaction as needed for the web according to the beam's coped condition.

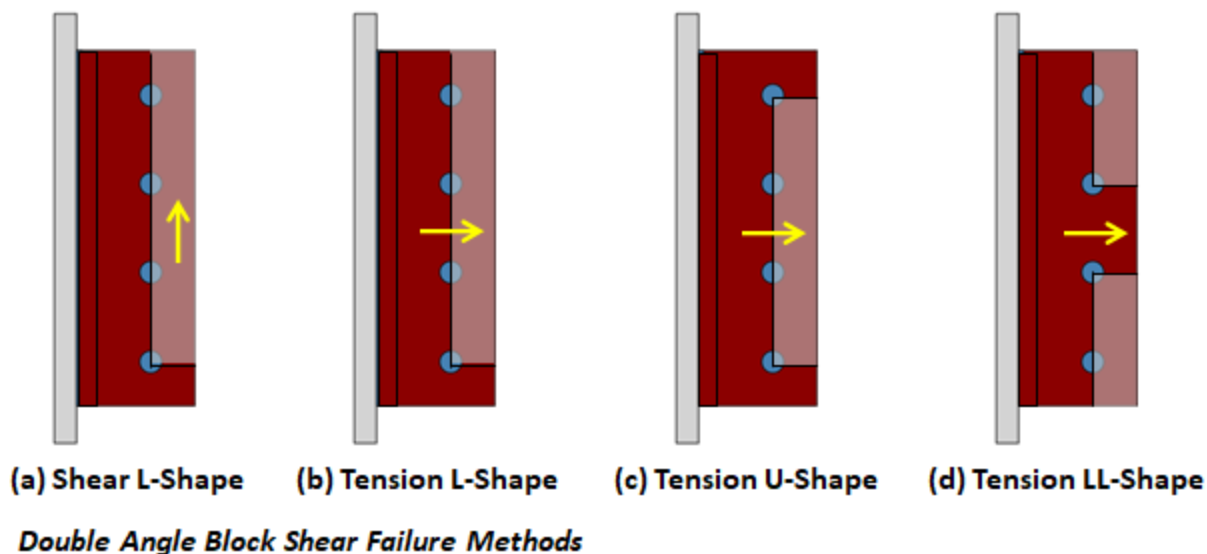

## 1.11 Double Angle Bolted Welded Design

Double Angle Bolted Welded (i.e. bolted to the support and welded to the beam) connections are used to connect steel beams to column or girders. VACONNECT is capable of designing these connections to support coped beams and to resist both shear and axial loads.

### Design Considerations

#### Connection Eccentricity

Double Angle Bolted Welded connections are checked per the AISC Steel Construction Manual Part 10 (16th Edition) and AISC 360-22 design specifications. In accordance with AISC part 10, the eccentricity on the supported side of the double-angle connection (i.e. the beam side) is always considered since the double angles are welded to the beam. VACONNECT accounts for eccentricity using the Instantaneous Center of Rotation method to determine the eccentric weld group capacity at the beam side of the double angles and at the web of the beam. The "C" coefficients for eccentrically loaded weld groups are included in the detailed reports.

VACONNECT assumes that the pin (which allows for rotational ductility) occurs at the face of the support. Therefore, eccentricity at the faying surface of the double angles and the support is not considered. While VACONNECT limits the maximum thickness of the double angle connection to 5/8 inches to allow for flexibility in the connection, the workable gage of the bolts to the support is not specifically checked in the program.

#### Combined Forces

VACONNECT also allows double angle bolted welded connections to be designed for combined eccentric shear force (force in-plane and parallel to the depth of the beam's web) and axial force (force in-plane and perpendicular to depth of the beam's web) according to the AISC Steel Construction Manual Part 12 (16th Edition) and closely following Example II.A-2B of the AISC Design Examples Version 16.0. Bolt shear and tension interaction (including prying) and biaxial block shear interaction are both accounted for according to the example.

Since the AISC Design Examples Version 16.0 does not explicitly address this combined force condition for double angles bolted welded connections when the beam has a significant offset, VACONNECT uses the methods outlined in Example II.A-19B (Extended single-plate connection subject to axial and shear loading) to design the legs of the angles that are connected to the beam for combined eccentric shear and axial force. Specifically, the interaction of the shear,

axial, and flexural loads are considered for both the yielding/buckling limit state and for the rupture limit state. The program's detailed reports clearly document how the various limit states are checked.

## Coped Beams

Beams coped at one or both flanges are checked per the AISC Steel Construction Manual Part 9 (16th Edition) and AISC 360-22 design specifications. The 16th Edition of the AISC Steel Construction Manual does not explicitly address how to design coped beams for combined shear and axial loading. Therefore, VAConnect uses the same methodology as the shear tab in Part 12 of the AISC Steel Construction Manual (16th Edition) and in Example II.A-19B of the AISC Design Examples Version 16.0 to account for the interaction of the shear, axial, and flexural loads for both the yielding/buckling and the rupture cases of the coped beam. Furthermore, the interaction for biaxial block shear on the coped beam is accounted for according to the aforementioned example.

## Limit States

VAConnect checks the following limit states for Double Angle Bolted Welded Connections (refer to the program's detailed reports for specific code references):

- **Bolts**
  - Bolt Tension w/ Shear & Prying - Support
  - Bolt Group Capacity (Shear, Bearing, & Tearout) - Support
  - Bolt Group Capacity (Shear, Bearing, & Tearout) - 2L @ Support
  - Block Shear - 2L @ Support
- **Welds**
  - Fillet Weld - 2L @ Beam
  - Base Metal - 2L @ Beam
  - Base Metal - Beam Web
  - Block Shear - Beam Web
- **Double Angle**
  - Shear Yield - 2L @ Support
  - Shear Yield - 2L @ Beam
  - Tension Yield - 2L @ Beam
  - Compression Buckling - 2L @ Beam
  - Flexural Yielding/Buckling - 2L @ Beam
  - Yielding/Buckling Interaction - 2L @ Beam
  - Shear Rupture - 2L @ Support
  - Shear Rupture- 2L @ Beam
  - Tension Rupture- 2L @ Beam
  - Flexural Rupture - 2L @ Beam
  - Rupture Interaction - 2L @ Beam
- **Beam**
  - Shear Yield
  - Tension Yield
  - Compression Buckling
  - Flexural Yielding/Buckling
  - Yielding/Buckling Interaction
  - Shear Rupture

- Tension Rupture
- Flexural Rupture
- Rupture Interaction
- **Connection Detailing**
  - Double angle maximum length
  - Maximum angle thickness
  - Maximum and minimum bolt spacing
  - Maximum and minimum bolt edge distances
  - Fillet weld maximum and minimum size

## Limitations

- Permitted beam shapes: I-Beams and Channels
- Permitted supporting member shapes: I-Beams, Channels, HSS, Pipe, Rectangle, or Round. The support member is only limited when importing from VisualAnalysis.
- The support element is only considered as far as it affects the bolt design (e.g. bolt shear, bearing, and tearout at the support)
- The eccentricity at the faying surface of the double angles and the support is not considered as the pin which allows for rotational ductility is assumed to occur at the face of the support
- Beam is nearly perpendicular to the column or girder
- A single member framing into a support column or girder
- Only a single vertical row of bolts is allowed in each angle at the support
- Single coped channels are not supported
- Only standard bolt holes are supported
- Only forces in the plane of the connection (shear and axial) can be checked
- When an unrecognized beam is imported from VisualAnalysis, the beam's T dimension is assumed to be the depth minus twice the flange thickness (i.e. the fillets are neglected)

## 1.12 Double Angle Welded Design

Double Angle Welded connections are used to connect steel beams to columns or girders. VACONnect is capable of designing these connections to support coped beams and to resist shear loads.

### Design Considerations

#### Connection Eccentricity

Double Angle Welded connections are checked per the AISC Steel Construction Manual Part 10 (16th Edition) and AISC 360-22 design specifications. In accordance with AISC part 10, the eccentricity on the supported side of the double-angle connection (i.e. the beam side) is always considered since the double angles are welded to the beam. Furthermore, VACONnect accounts for the weld eccentricity on the supporting side of the double-angle connection (i.e. the support side). VACONnect accounts for eccentrically loaded weld groups using the Instantaneous Center of Rotation method to determine the eccentric weld group capacity and for the base metal checks. The "C" coefficients for both eccentrically loaded weld groups (i.e. the beam weld and the support weld) are included in the detailed reports. This connection closely follows Example II.A-3 of the AISC Design Examples Version 16.0.

VACONnect assumes that the pin (which allows for rotational ductility) occurs at the face of the support. Therefore, eccentricity at the faying surface of the double angles and the support is not considered. VACONnect limits the

maximum thickness of the double angle connection to 5/8 inches to allow for flexibility in the connection. While VAConnect allows welding along the bottom of the double angles, it does not allow for welding along the top as welding across the entire top of the angles inhibits the flexibility and necessary end rotation of the connection, according to the AISC Steel Construction Manual Part 10.

## Combined Forces

VAConnect does not allow double angles welded to the support to be loaded with axial force. According to the AISC Steel Construction Manual Part 12 (16th Edition), double angle connections with welds on the outstanding legs provide minimal strength to resist axial loads due to the flexural loading that is applied about the longitudinal axis of these welds.

## Coped Beams

Beams coped at one or both flanges are checked per the AISC Steel Construction Manual Part 9 (16th Edition) and AISC 360-22 design specifications.

## Limit States

VAConnect checks the following limit states for Double Angle Welded Connections (refer to the program's detailed reports for specific code references):

- **Support Welds**
  - Fillet Weld - 2L @ Support
  - Base Metal - 2L @ Support
  - Base Metal - Support
- **Beam Welds**
  - Fillet Weld - 2L @ Beam
  - Base Metal - 2L @ Beam
  - Base Metal - Beam Web
  - Block Shear - Beam Web
- **Double Angle**
  - Shear Yield - 2L @ Beam
  - Flexural Yielding/Buckling - 2L @ Beam
  - Yielding/Buckling Interaction - 2L @ Beam
  - Shear Rupture- 2L @ Beam
  - Flexural Rupture - 2L @ Beam
  - Rupture Interaction - 2L @ Beam
- **Beam**
  - Shear Yield
  - Flexural Yielding/Buckling
  - Yielding/Buckling Interaction
  - Shear Rupture
  - Flexural Rupture
  - Rupture Interaction
- **Connection Detailing**
  - Double angle maximum length
  - Maximum angle thickness

- Fillet weld maximum and minimum size

## Limitations

- Permitted beam shapes: I-Beams and Channels
- Permitted supporting member shapes: I-Beams, Channels, HSS, Pipe, Rectangle, or Round. The support member is only limited when importing from VisualAnalysis.
- The support element is only considered as far as it affects the weld design (e.g. base metal check at the support)
- The eccentricity at the faying surface of the double angles and the support is not considered as the pin which allows for rotational ductility is assumed to occur at the face of the support
- Beam is nearly perpendicular to the column or girder
- A single member framing into a support column or girder
- Single coped channels are not supported
- Only shear forces in the plane of the connection can be checked
- When an unrecognized beam is imported from VisualAnalysis, the beam's T dimension is assumed to be the depth minus twice the flange thickness (i.e. the fillets are neglected)

## 1.13 Double Angle Welded Bolted Design

Double Angle Welded Bolted (i.e. welded to the support and bolted to the beam) connections are used to connect steel beams to column or girders. VACONNECT is capable of designing these connections to support coped beams and to resist shear loads.

### Design Considerations

#### Connection Eccentricity

Double Angle Welded Bolted connections are checked per the AISC Steel Construction Manual Part 10 (16th Edition) and AISC 360-22 design specifications. In accordance with AISC part 10, the eccentricity on the supported side of the double-angle connection (i.e. the beam side) is neglected when a single vertical row of bolts through the beam does not exceed a distance of 3 inches from the face of the support. When this condition is not met, VACONNECT accounts for the eccentricity using the Instantaneous Center of Rotation method to determine the eccentric bolt group capacity (shear, bearing, and tearout) at the beam side of the double angle and at the web of the beam. Furthermore, VACONNECT accounts for the weld eccentricity on the supporting side of the double-angle connection (i.e. the support side). VACONNECT also accounts for eccentrically loaded weld groups using the Instantaneous Center of Rotation method to determine the eccentric weld group capacity and for the base metal checks. The "C" coefficients for both the eccentrically loaded weld group and the eccentrically loaded bolt group are included in the detailed reports. This connection closely follows Example II.A-2A of the AISC Design Examples Version 16.0.

VACONNECT assumes that the pin (which allows for rotational ductility) occurs at the face of the support. Therefore, eccentricity at the faying surface of the double angles and the support is not considered. VACONNECT limits the maximum thickness of the double angle connection to 5/8 inches to allow for flexibility in the connection. While VACONNECT allows welding along the bottom of the double angles, it does not allow for welding along the top as welding across the entire top of the angles inhibits the flexibility and necessary end rotation of the connection, according to the AISC Steel Construction Manual Part 10.

#### Combined Forces

VACONNECT does not allow double angles welded to the support to be loaded with axial force. According to the AISC

Steel Construction Manual Part 12 (16th Edition), double angle connections with welds on the outstanding legs provide minimal strength due to the flexural loading that is applied about the longitudinal axis of these welds.

## Coped Beams

Beams coped at one or both flanges are checked per the AISC Steel Construction Manual Part 9 (16th Edition) and AISC 360-22 design specifications.

## Limit States

VAConnect checks the following limit states for Double Angle Welded Bolted Connections (refer to the program's detailed reports for specific code references):

- **Welds**
  - Fillet Weld
  - Base Metal - 2L
  - Base Metal - Support
- **Bolts**
  - Bolt Group Capacity (Shear, Bearing, & Tearout) - 2L @ Beam
  - Bolt Group Capacity (Shear, Bearing, & Tearout) - Beam Web
  - Block Shear - 2L @ Beam
  - Block Shear - Beam Web
- **Double Angle**
  - Shear Yield - 2L @ Beam
  - Flexural Yielding/Buckling - 2L @ Beam
  - Yielding/Buckling Interaction - 2L @ Beam
  - Shear Rupture- 2L @ Beam
  - Flexural Rupture - 2L @ Beam
  - Rupture Interaction - 2L @ Beam
- **Beam**
  - Shear Yield
  - Flexural Yielding/Buckling
  - Yielding/Buckling Interaction
  - Shear Rupture
  - Flexural Rupture
  - Rupture Interaction
- **Connection Detailing**
  - Double angle maximum length
  - Maximum angle thickness
  - Maximum and minimum bolt spacing
  - Maximum and minimum bolt edge distances
  - Fillet weld maximum and minimum size

## Limitations

- Permitted beam shapes: I-Beams and Channels
- Permitted supporting member shapes: I-Beams, Channels, HSS, Pipe, Rectangle, or Round. The support

member is only limited when importing from VisualAnalysis.

- The support element is only considered as far as it affects the weld design (e.g. base metal check at the support)
- The eccentricity at the faying surface of the double angles and the support is not considered as the pin which allows for rotational ductility is assumed to occur at the face of the support
- Beam is nearly perpendicular to the column or girder
- A single member framing into a support column or girder
- Single coped channels are not supported
- Only a single or double vertical row of bolts is allowed at the beam
- Only standard bolt holes are supported
- Only shear forces in the plane of the connection can be checked
- When an unrecognized beam is imported from VisualAnalysis, the beam's T dimension is assumed to be the depth minus twice the flange thickness (i.e. the fillets are neglected)

## Block Shear

The figure below shows the possible block shear failure methods that VAConnect checks for the double angles. In addition to checking each case (a through d) independently, the interaction for block shear failure from combined shear and tension is considered. While combined block shear only needs to be checked for case a and case b in the figure below, VAConnect conservatively uses the lowest capacity from case b through case d for tension to combine with case a for shear. VAConnect checks the appropriate block shear failure methods and block shear interaction as needed for the web according to the beam's coped condition.

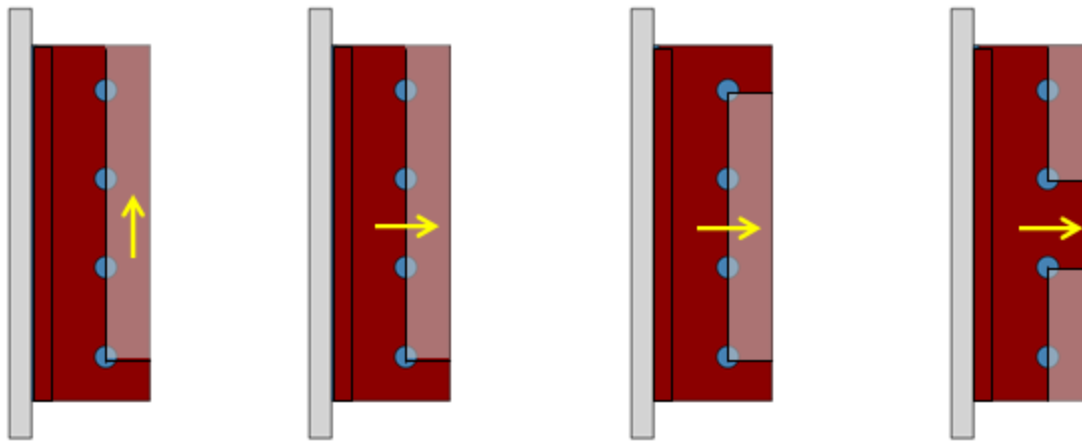

**(a) Shear L-Shape    (b) Tension L-Shape    (c) Tension U-Shape    (d) Tension LL-Shape**

### *Double Angle Block Shear Failure Methods*

## 1.14 Welded Flange Plate Design

A Welded Flange Plate connection consists of two steel plates that are welded to both the support and the flanges of the beam to resist moment. VAConnect assumes that the Welded Flange Plate connections possess sufficient rigidity to maintain the angles between the connected members and behave as fully restrained moment connections as discussed in the AISC Steel Construction Manual Part 12. While various simple shear connections can be used in conjunction with welded flange plates, VAConnect uses a shear tab to resist the applied shear loads.

## Design Considerations



Welded Flange Plate connections are checked per the AISC 360-22 design specification. VAConnect allows the flange plates to be connected to the support with either a double sided fillet weld or a complete-joint-penetration groove weld. The capacity of the complete-joint-penetration groove welds are not checked since the strength of the joint is controlled by the base metal according to AISC 360-22 Table J2.5. The length of the weld at the support can be manually set to a value less than the width of the flange plate, which is needed for cases when the flange plate is wider than the support. Fillet weld are used to connect the flange plates to the flanges of the beam. The end weld (i.e. the weld along the back edge of the flange plate perpendicular to the beam's span) can be enabled or disabled. When the end weld is disabled, the weld group is two parallel lines and when enabled the weld group is a U-shape. To avoid overhead welding in the field, the top flange plate is typically narrower than the beam's top flange (with an end weld) while the bottom flange plate is typically wider than the beam's bottom flange without an end weld. To allow enough room for placement of the fillet welds, VAConnect requires the difference between the width of the flange plate and the width of the beam's flange to be greater than or equal to two times the size of the weld.

## Load Distribution - Moment, Axial, & Shear

Shear is transferred from the web of the beam to the support through the shear tab connection. Since the angle between the beam and the support in a fully restrained moment connection remains unchanged under loading, eccentricity is neglected when checking limit states pertaining to the shear tab.<sup>3</sup> To satisfy equilibrium, the moment from the eccentric shear force (eccentricity  $\cdot F_v$ ) is added to the moment applied to the connection ( $M_z$ ). The axial force is assumed to be distributed uniformly to the flanges of the beams (the shear tab connection is therefore assumed to have negligible axial stiffness compared to the flange plate connections). The moment at the connection is resolved into an effective tension-compression couple acting as axial forces at the beam flanges. Finally, the forces in the flanges plates can be calculated as  $R = (M_z + \text{eccentricity} \cdot F_v) / d \pm F_a/2$ .

## Limit States

VAConnect checks the following limit states for Welded Flange Plates (refer to the program's detailed reports for specific code references):

- **Shear Tab**
  - Bolt Group Capacity (Shear, Bearing, & Tearout)
  - Bolt Group Capacity (Shear, Bearing, & Tearout) - Beam Web
  - Fillet Weld
  - Base Metal
  - Base Metal - Support
  - Block Shear
  - Shear Yield
  - Shear Rupture
- **Top & Bottom Flange Plate**
  - Tension Yield
  - Tension Rupture
  - Compression Buckling
  - Block Shear
  - Fillet Weld - Plate to Flange
  - Base Metal
  - Base Metal - Flange
  - Weld - Plate to Support
  - Base Metal

## • Connection Detailing

- Shear tab maximum plate height
- Shear tab maximum plate thickness
- Shear tab fillet weld maximum and minimum size
- Shear tab number of fillet weld lines
- Welds are adequate to developed shear tab strength
- Maximum and minimum bolt spacing
- Maximum and minimum bolt edge distances
- Flange plate fillet weld maximum and minimum size
- Flange plate's width-to-thickness ratio is nonslender

## Limitations

- Permitted beam shapes: I-Beams
- Permitted supporting member shapes: I-Beams, Channels, HSS, Pipe, or Rectangle. The support member is only limited when importing from VisualAnalysis.
- The support element is only considered as far as it affects the weld design (e.g. base metal check, minimum and maximum fillet weld sizes)
- Weld base metal checks assume that there is not a connection on the opposite side of the support
- Beam is nearly perpendicular to the support
- A single member framing into a support
- Only a single vertical row of bolts is allowed for the shear tab
- Web and flange yield and rupture are not supported
- Only standard bolt holes are supported
- Only forces in the plane of the connection (shear, axial, and moment) can be checked
- When an unrecognized beam is imported from VisualAnalysis, the beam's T dimension is assumed to be the depth minus twice the flange thickness (i.e. the fillets are neglected)
- Only fillet welds and complete-joint-penetration groove weld are allowed at the support (partial-joint-penetration groove weld are not supported)
- The flange plates are assumed to resist the moment and axial load and no shear

## Block Shear

The block shear failure method at the plate-to-flange connection depends on the both the end weld condition and the relative width of the plate to the flange. VAConnect automatically checks the all of the applicable block shear cases as outlined in the figures below.

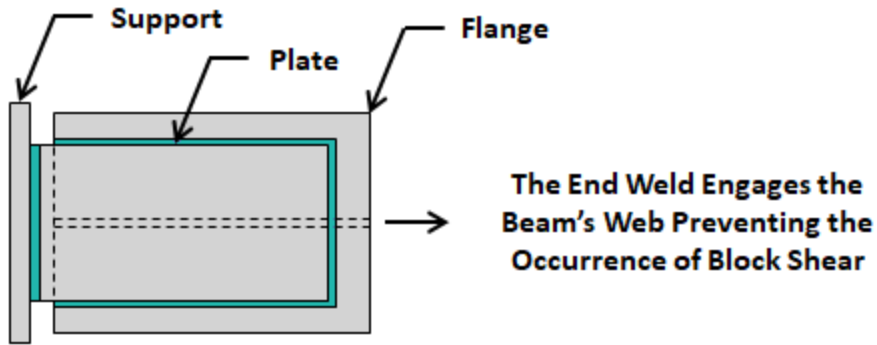

*Block Shear Failure Modes – End Weld & Plate Width < Flange Width*

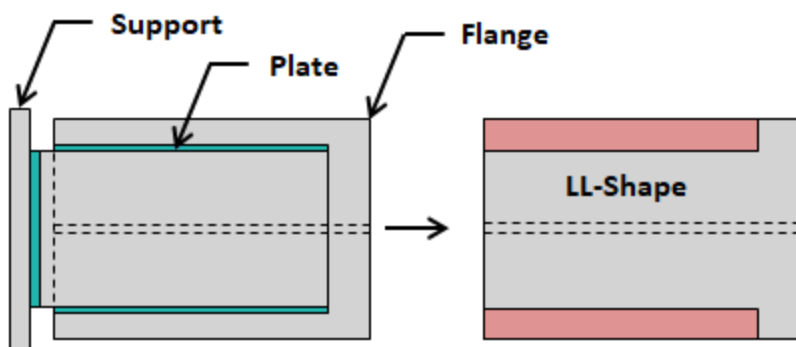

*Block Shear Failure Modes – No End Weld & Plate Width < Flange Width*

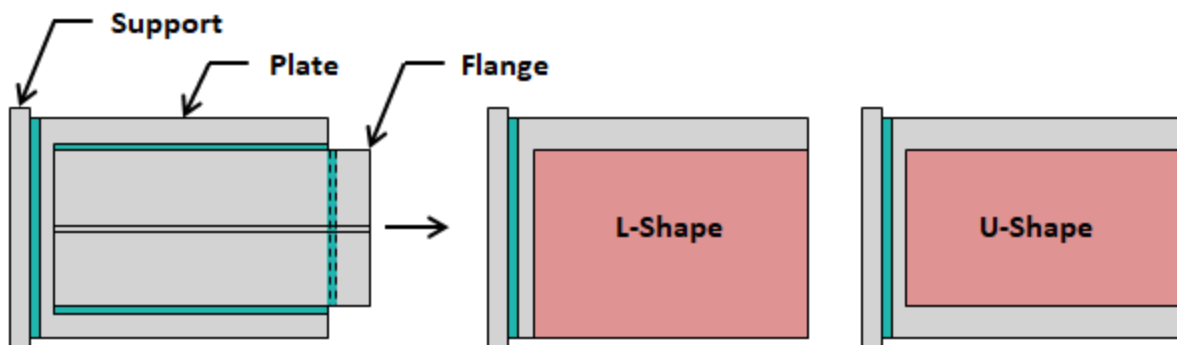

*Block Shear Failure Modes – End Weld & Plate Width > Flange Width*

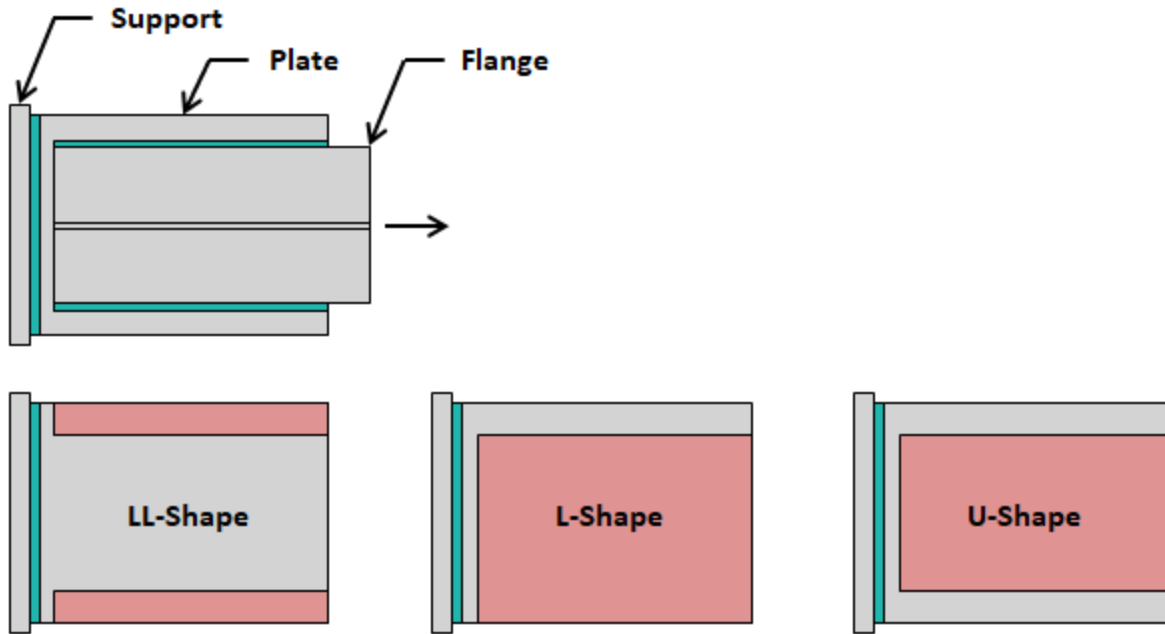

**Block Shear Failure Modes – No End Weld & Plate Width > Flange Width**

## 1.15 Bolted Flange Plate Design

A Bolted Flange Plate connection consists of two steel plates that are welded to the support and bolted to the flanges of the beam to resist moment. VAConnect assumes that the Bolted Flange Plate connections possess sufficient rigidity to maintain the angles between the connected members and behave as fully restrained moment connections as discussed in the AISC Steel Construction Manual Part 12. While various simple shear connections can be used in conjunction with bolted flange plates, VAConnect uses a shear tab to resist the applied shear loads.

### Design Considerations

Bolted Flange Plate connections are checked per the AISC 360-22 design specification. Bolts are used to connect the flange plates to the flanges of the beam. VAConnect requires that the same Bolted Flange Plate connection be made at the top and bottom flange of the beam (i.e. the connection will be symmetrical about the centerline of the beam). VAConnect allows the flange plates to be connected to the support with either a double sided fillet weld or a complete-joint-penetration groove weld. The capacity of the complete-joint-penetration groove welds are not checked since the strength of the joint is controlled by the base metal according to AISC 360-22 Table J2.5. The length of the weld at the support can be manually set to a value less than the width of the flange plate, which is needed for cases when the flange plate is wider than the support.

### Load Distribution - Moment, Axial, & Shear

Shear is transferred from the web of the beam to the support through the shear tab connection. Since the angle between the beam and the support in a fully restrained moment connection remains unchanged under loading, eccentricity is neglected when checking limit states pertaining to the shear tab.<sup>3</sup> To satisfy equilibrium, the moment from the eccentric shear force (eccentricity  $\cdot F_v$ ) is added to the moment applied to the connection ( $M_2$ ). The axial force is assumed to be distributed uniformly to the flanges of the beams (the shear tab connection is therefore assumed to have negligible axial stiffness compared to the flange plate connections). The moment at the connection is resolved into an effective tension-compression couple acting as axial forces at the beam flanges. Finally, the forces in the flanges plates

can be calculated as  $R = (M_z + \text{eccentricity} \cdot F_v) / d \pm F_a/2$ .

## Limit States

VAConnect checks the following limit states for Bolted Flange Plates (refer to the program's detailed reports for specific code references):

- **Shear Tab**
  - Bolt Group Capacity (Shear, Bearing, & Tearout)
  - Bolt Group Capacity (Shear, Bearing, & Tearout) - Beam Web
  - Fillet Weld
  - Base Metal
  - Base Metal - Support
  - Block Shear
  - Shear Yield
  - Shear Rupture
- **Top & Bottom Flange Plate**
  - Tension Yield
  - Tension Rupture
  - Tension Rupture - Flange
  - Compression Buckling
  - Block Shear
  - Block Shear - Flange
  - Bolt Group Capacity (Shear, Bearing, & Tearout)
  - Bolt Group Capacity (Shear, Bearing, & Tearout) - Flange
  - Weld
  - Base Metal
- **Connection Detailing**
  - Shear tab maximum plate height
  - Shear tab maximum plate thickness
  - Shear tab fillet weld maximum and minimum size
  - Shear tab number of fillet weld lines
  - Welds are adequate to developed shear tab strength
  - Shear tab and flange plate maximum and minimum bolt spacing
  - Shear tab and flange plate maximum and minimum bolt edge distances
  - Flange plate fillet weld maximum and minimum size
  - Flange plate's width-to-thickness ratio is nonslender

## Limitations

- Permitted beam shapes: I-Beams
- Permitted supporting member shapes: I-Beams, Channels, HSS, Pipe, or Rectangle. The support member is only limited when importing from VisualAnalysis.
- The support element is only considered as far as it affects the weld design (e.g. base metal check, minimum and maximum fillet weld sizes)
- Weld base metal checks assume that there is not a connection on the opposite side of the support

- Beam is nearly perpendicular to the support
- A single member framing into a support
- Only a single vertical row of bolts is allowed for the shear tab
- Web yield and rupture are not supported
- Only standard bolt holes are supported
- Only forces in the plane of the connection (shear, axial, and moment) can be checked
- When an unrecognized beam is imported from VisualAnalysis, the beam's T dimension is assumed to be the depth minus twice the flange thickness (i.e. the fillets are neglected)
- Only fillet welds and complete-joint-penetration groove weld are allowed at the support (partial-joint-penetration groove weld are not supported)
- The flange plates are assumed to resist the moment and axial load and no shear

## Block Shear

The figure below shows the possible block shear failure methods that VAConnect checks at the plate-to-flange connection.

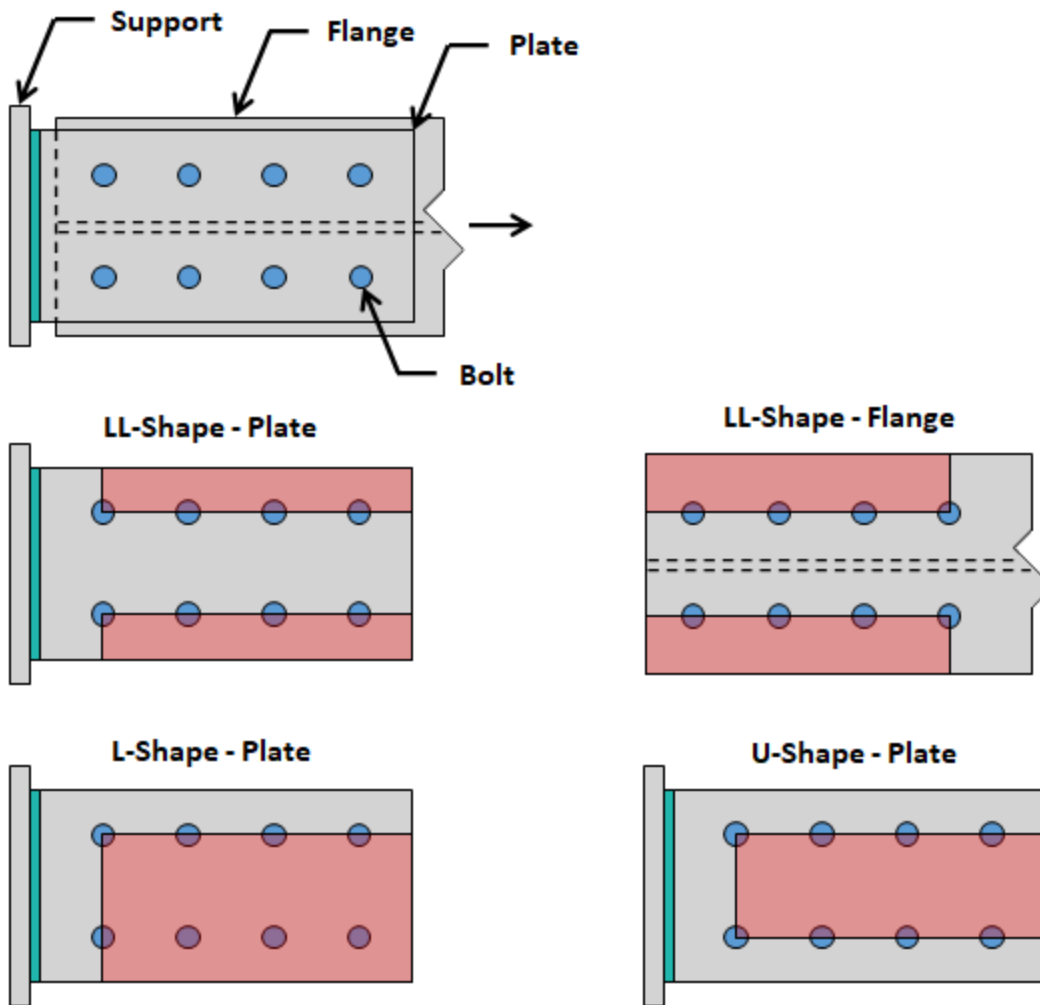

**Block Shear Failure Modes**

## 1.16 Bolted End Plate Design

A bolted end plate moment connection consists of a steel plate welded to the end of a beam section with attachment to a column using rows of fully tensioned high-strength bolts. VAConnect assumes that bolted end plate connections possess sufficient rigidity to maintain the angles between the connected members and behave as fully restrained moment connections (FR) as discussed in the AISC Steel Construction Manual Part 12. VAConnect supports the following configurations using the design procedures of AISC Design Guide 4, Extended End-Plate Moment Connections - Seismic and Wind Applications, as well as the AISC 360-22 design specification and the AISC Manual, 16th Edition.

- Four Bolt Unstiffened (4E)
- Four Bolt Stiffened (4ES)
- Eight Bolt Stiffened (8ES)

### Design Considerations

The AISC Design Guide 4 procedure uses a yield-line analysis to design the end plate and column flange to ensure that both remain elastic and thick plate behavior is achieved. With thick plate behavior, the bolts are not subject to significant prying forces

#### Bolt Force Model

The flexural strength of the connection is based upon the bolt tension rupture and is determined by taking the static moment of the bolt strengths about the centerline of the compression flange as shown in the Figure below. This is termed the *No Pry Bolt Tension Rupture Strength*.

No Pry Bolt Tension Rupture Strength

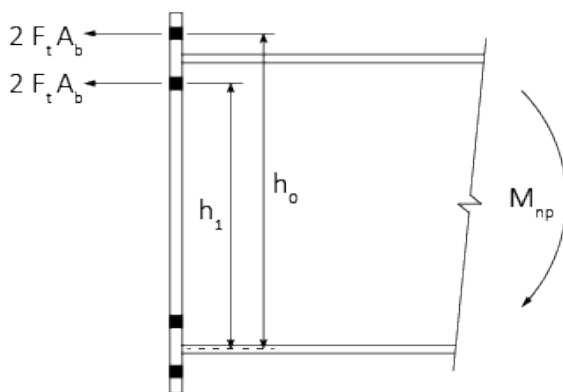

4 Bolt Configuration

$$\phi M_{np} = \phi 2 F_t A_b (h_o + h_1)$$

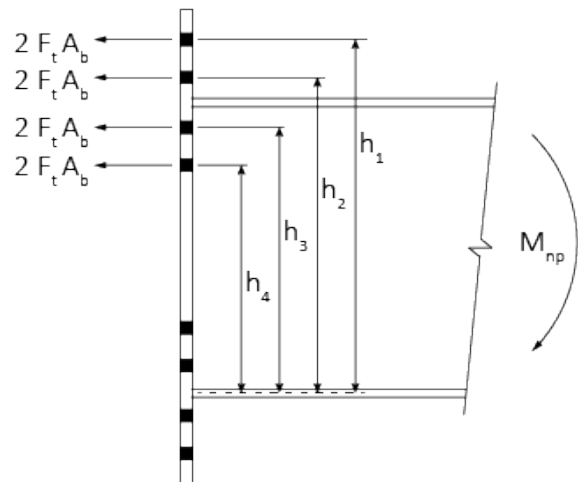

8 Bolt Configuration

$$\phi M_{np} = \phi 2 F_t A_b (h_1 + h_2 + h_3 + h_4)$$

To ensure thick plate behavior, the no prying strength of the bolts must be less than or equal to 90% of the end plate and column flange strength. Another way to state this requirement is that the end plate and column flange strength must be greater than or equal to 111% of the strength of the bolts, as shown below.

$$M_u = 1.11 * \phi M_{np} < \phi M_n \quad (\text{Yield Line Capacity of End Plate and Column Flange})$$

## Yield Line Theory

Design Guide 4 provides an overview of the Yield Line Theory used to develop the end plate and column flange bending strengths. Per Design Guide 4 the following simplifications have been incorporated into the yield line equations to reduce the complexity of the yield line equations:

- No adjustment in end plate or column flange strength is made to account for the plate material removed by bolt holes.
- The width of the beam or column web is considered to be zero in the yield line equations.
- The width of fillet welds along the flange or stiffeners and web is not considered in the yield line equations.
- The strength contribution from yield lines in the compression region of the connections is neglected.

## Column Side Design

VACONnect checks the limit states of Column Flange Flexural Yielding, Column Web Yielding, Column Web Buckling, and Column Web Crippling to determine if column transverse stiffeners (continuity plates) are required. When the Beam Flange Force ( $F_{fu}$ ) exceed the column side capacity ( $\phi R_n$ ) of any of the previously listed limit states, continuity plates are required for the column design. The corresponding Stiffener Design Force ( $F_{su}$ ) that is reported in VACONnect is calculated as follows:

$$F_{su} = F_{fu} - \min \phi R_n$$

where  $\min \phi R_n$  is the minimum design strength value from the limit states of:

- Column Flange Yielding
- Column Web Yielding
- Column Web Buckling
- Column Web Crippling

When continuity plates are required for design, additional considerations per AISC 360 and Design Guide 13 are required and are deemed beyond the scope of VACONnect. Additionally, column panel zone checks, such as shear yielding and plate buckling, are beyond the scope of VACONnect, and require further consideration by the designer.

## Limit States

VACONnect checks the following limit states for Bolted End Plate connections (refer to the program's detailed reports for specific code references):

- **End Plate**
  - Flexural Yield (Yield Line Mechanism)
  - Shear Yield (4E Configuration only)
  - Shear Rupture (4E Configuration only)
  - Bolt Capacity (Shear, Bearing, & Tearout)
  - Stiffener Thickness (4ES & 8ES configurations only)
  - Stiffener Welds (4ES & 8ES configurations only)
- **Bolts**
  - Tension Rupture
- **Connected Beam**
  - Flange Weld (Tension)
  - Web Weld (Shear, Base Metal, Tension)



- **Column**
  - Flange Flexural Yield (Yield Line Mechanism)
  - Bolt Capacity (Shear, Bearing, & Tearout)
  - Web Yield
  - Web Buckling
  - Web Crippling

## Design Assumptions

VAConnect makes the following design assumptions for Bolted End Plate connections based on AISC Design Guide 4 and AISC Manual Part 12 provisions:

- The bolts are tightened to a pretension not less than that given in the current AISC specification; however, slip-critical requirements are not needed.
- Group A or B high-strength bolts of diameter not greater than 1.5 in. must be used.
- The specified minimum yield stress of the end plate material must be 50 ksi or less.
- All the shear force is assumed to be resisted by the compression side bolts.
- The end plate width effective in resisting the applied moment must be taken as not greater than the beam flange width plus 1.0 inch. This assumption is based on engineering judgment.
- The gauge of the bolts (horizontal distance between vertical bolt lines) must not exceed the beam's flange width.
- When fillet welds are used for the beam flange-to-end plate welds, the welds are designed for the calculated flange force ( $F_{fu}$ ) but not less than 60% of the factored tensile yield strength of the beam flange. This recommended minimum weld strength is based on engineering judgment and intended to preclude small weld sizes on comparatively larger beams that may have been sized for stiffness, and to account for the variations in the distribution of flange forces across the weld length.
- The beam web-to-end plate welds in the vicinity of the tension bolts are designed to develop the yield stress of the beam web.
- Only the web-to-end plate weld between the mid-depth of the beam and the inside face of the beam compression flange, or the weld between the inner row of tension bolts plus 2 bolt diameters and the inside face of the beam compression flange, whichever is smaller, is considered effective in resisting the beam end shear. According to Design Guide 4, this assumption is based on engineering judgment; literature is not available to substantiate or contradict this assumption.
- The minimum distance from the face of the beam flange to the bolt centerline (the vertical bolt pitch) is the bolt diameter,  $d_b$ , plus 1/2 in. if the diameter is not greater than 1 in., and plus 3/4 in. for larger diameter bolts.
- When CJP welds are used, weld access holes should not be used.
- A 5/16" fillet backing weld is provided when CJP welds are used at the beam flanges.
- Column continuity plates are not considered effective in resisting bolt tearout.
- For the outer row of bolts, tearout is only considered when the bolts in compression tend to tearout towards the bolts in tension.
- When present, the column cap plate is assumed to prevent vertical tearout of the top row of bolts.
- In the 4ES and 8ES configurations, stiffener geometry is assumed to meet the recommendations of AISC Design Guide 4 Section 2.4 and Figure 2.8.

## Limitations

- Permitted beam and column shapes: wide flange "I-Beams"
- Beam is perpendicular to the support column

- Only standard bolt holes are supported
- Only forces in the plane of the connection (shear and moment) can be checked
- A single beam is framing into the support column
- When an unrecognized beam is imported from VisualAnalysis, the beam's T dimension is assumed to be the depth minus twice the flange thickness (i.e. the fillets are neglected)
- When the beam is located near the top of the column, a column cap plate of the same thickness as the beam flange is assumed to be present
- Only fillet welds and complete-joint-penetration groove weld are allowed at the end plate (partial-joint-penetration groove weld are not supported)
- Weld base metal checks are not included for the beam flange
- The bolt gauge is not checked against the column's workable gauge
- Bolt entering and tightening clearances are not checked

## 1.17 Column Splice Design

The column splice design module consists of an upper and lower wide flange steel column, steel splice plates at the column flanges, and connecting bolts.

### Design Considerations<sup>4</sup>

#### Flange-Plated Column Splices

Full contact bearing in flange-plated column splices is always achieved when lighter sections are centered over heavier sections of the same nominal depth group. When the upper column depth is of a smaller nominal depth than the lower column, unfinished fillers may be used to "pack-out" the gap between the column flange and the splice plate. Since no force is transferred by these fillers, they are not included in the column splice design within VAConnect.

#### Force Transfer

For the W-shapes most frequently used as columns, the distance between the inner faces of the flanges is constant throughout any given nominal depth group. VAConnect assumes that the ends of the columns are finished to bear on one another. The bearing strength of the projected bearing area of the column ends is much greater than the axial strength of the column per the AISC Specification and will seldom prove critical in the member design. For column splices transferring only compressive axial forces, complete force transfer may be achieved through bearing on finished surfaces and bolts or welds are only required by AISC to be sufficient to hold all parts securely in place. For this condition within VAConnect, only detailing checks are performed.

When shear and/or moment forces are applied to the connection, the limit states applicable to the strength of the splice plates, bolts, and column flanges will be calculated.

To determine the shear force on each bolt, the vector resultant of the direct shear force and the rotational shear force is calculated as shown below. Because the centroid of each bolt group is eccentric to the column ends, there will be a moment on each bolt group due to the applied shear force taken at the column ends.

Direct Shear Force per Bolt

$$\vec{V}_u = \frac{0.5 F_{ux}}{n_{bolts}} + \frac{1}{n_{bolts}} \left( 0.5 F_{uz} + \frac{M_{ux}}{d_{lower\ column}} \right)$$

Rotational Shear Force per Bolt

$$\vec{V}_u = \frac{M_u \times c_y}{I_p} + \frac{M_u \times c_x}{I_p}$$

Moment at Bolt Group Centroid

$$M_u = 0.5 F_{ux} \times ecc.$$

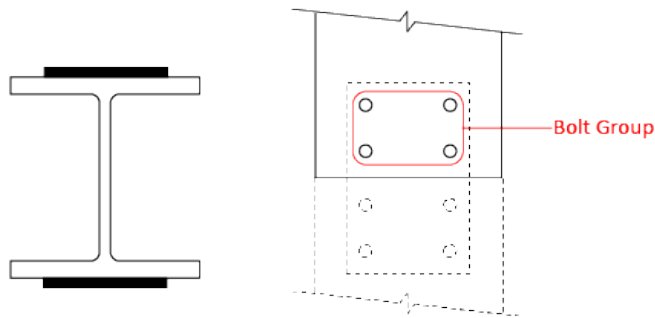

Resultant Design Shear Force per Bolt

$$\vec{V}_u = \vec{V}_{u-Direct} + \vec{V}_{u-Rotational}$$

To determine the tension force on each splice plate, the moment about the column's strong axis ( $M_x$ ) is decoupled into a tension and compression force using the width of the lower column and added to any applied tension force.

$$T_u = 0.5 F_{uz} + \frac{M_{ux}}{d_{lower\ column}}$$

## Limit States

VAConnect checks the following limit states for Column Splice connections (refer to the program's detailed reports for specific code references):

- **Splice Plates**

- Shear Yield Capacity
- Shear Rupture Capacity
- Tension Yield Capacity
- Tension Rupture Capacity
- Block Shear Rupture Capacity
- Flexural Yield Capacity

- **Bolts**

- Shear Capacity
- Bearing Capacity at the Bolt Holes - Splice Plate, Upper Column, Lower Column
- Bolt Tearout Capacity at the Bolt Holes - Splice Plate, Upper Column, Lower Column
- Bolt Pryout - Splice Plate

- **Column Flanges**

- Block Shear Rupture Capacity

Note that when a net tension force is present in the splice plates, the limit state of interaction between the tension, shear, and flexural forces is not considered and will need to be calculated outside of the program.

## Design Assumptions

VAConnect makes the following design assumptions for Column Splice connections:

- The upper column is assumed to be centered on lower column.
- The upper column is assumed to be finished to bear on the lower column (i.e. splice bolts/plates are not required to transfer compressive loads).
- The shear force parallel to the column's weak axis is resisted through weak axis flexural bending of the splice plates.
- The frictional resistance between the upper and lower columns due to dead load is conservatively ignored.

## Limitations

- The upper column depth must be within 2 inches of the lower column depth.
- The splice plate width cannot exceed the width of the upper column flange.
- The presence of erection holes or pin holes for lifting devices are not considered.
- Column stability during erection is not considered.
- Column lengths are not considered.
- Only wide flange column shapes are permitted.
- The location of the column splice is not considered. Where possible, column splices should be located at least 48 inches above finished floor elevation to accommodate the attachment of safety cables.
- Only standard bolt holes are supported.
- The bolt gauge is not checked against the column's workable gauge.
- Bolt entering and tightening clearances are not checked.
- Interaction between tension, shear, and flexural forces in the splice plate is not considered.

## 1.18 Beam Over HSS

A beam over HSS connection consists of a steel cap plate welded to the top of a HSS column section that supports the bottom flange of a W-shape beam. The cap plate is connected to the bottom flange of the beam via four bolts. The connection is intended to resist combined moments and axial load (in the HSS) without the presence of shear.

### Design Considerations

Beam Over HSS connections are checked per the AISC Steel Design Guide 24 and the AISC 360-22 design specification. In VAConnect, the limit states checked for the Beam Over HSS connection are based on those outline in Example 4.1 of Design Guide 24, which according to the design guide examines all of the limit states for this connection type. Note: As with the entire Design Guide 24, the scope is restricted to nonseismic applications.

### Force Model

The applied moment ( $M_u$ ) and axial load ( $P_u$ ) are resolved into two axial loads ( $C_u$  &  $T_u$  as determined from statics) that are transferred across the beam flange to cap plate interface. Compression forces ( $C_u$ ) are assumed to act at the face of the HSS whereas tensile forces ( $T_u$ ) act at the center of the bolts as shown in the image below. Depending on the magnitude and direction of the applied loads ( $M_u$  &  $P_u$ ), the forces that are transferred across the beam flange to cap plate interface may both be in compression or both be in tension. When both forces are compressive, only one wall of the HSS is considered to resist each of the compressive force.

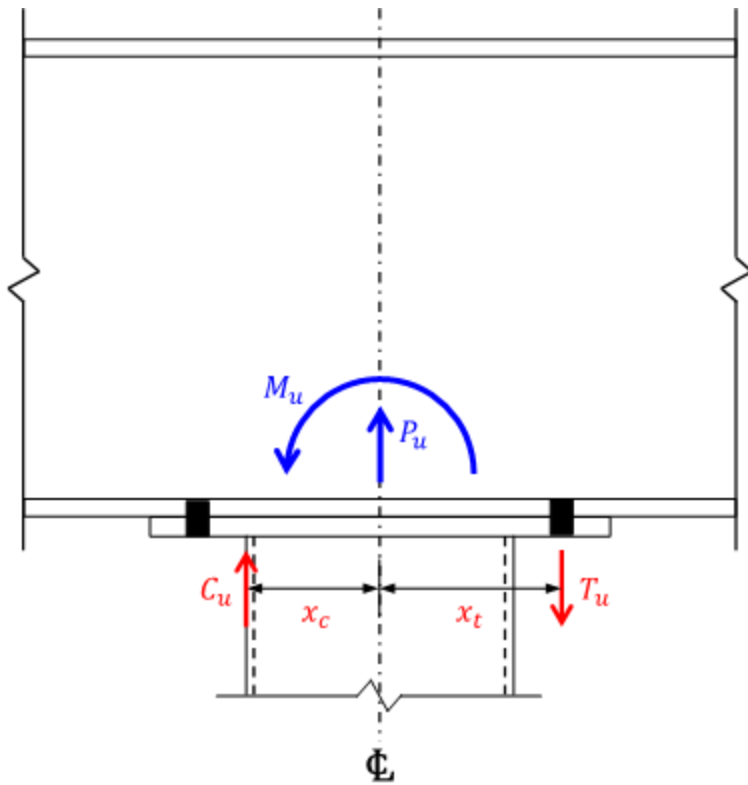

$$\Sigma F_Y = 0 \rightarrow P_u = T_u - C_u$$

$$\Sigma M = 0 \rightarrow M_u = x_c C_u + x_t T_u$$

*Beam Over HSS Connection Statics*

**Column at End of Beam**

The capacity of the beam side limit states (Web Local Yield, Web Local Crippling, & Web Compression Buckling) depends on the distance from the concentrated force to the end of the member. In some instances when the concentrated forces on both sides of the column are applicable for the limit state, the Unity Value (i.e. demand to capacity ratio) is checked for both concentrated and the worst case is reported.

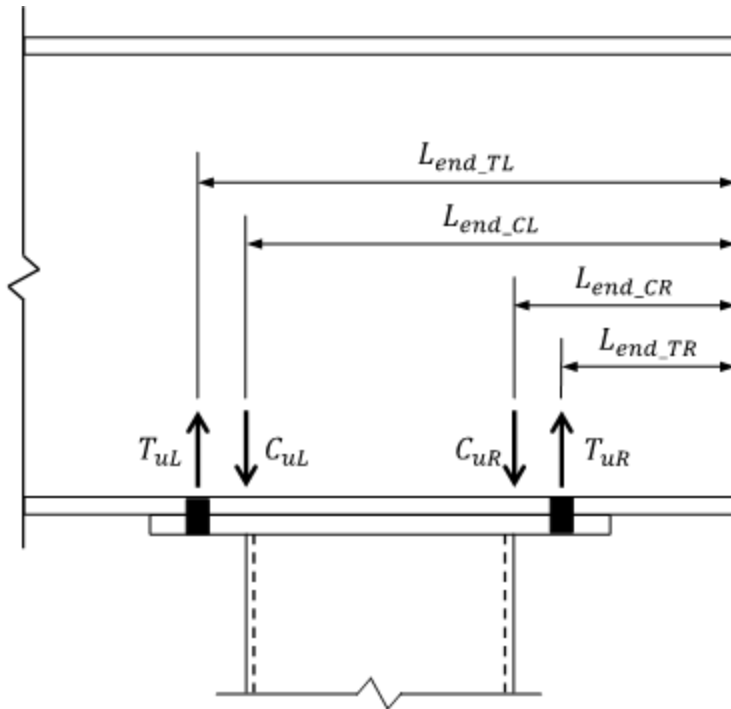

*Distance from Concentrated Force to Member End*

## Limit States

VACONNECT checks the following limit states for Bolted End Plate connections (refer to the program's detailed reports for specific code references):

- **Bolts**
  - Tension Rupture w/ Prying (from Beam Flange or Cap Plate)
- **Weld**
  - Fillet Weld Rupture w/ HSS and Cap Plate Base Metal checks
- **Beam**
  - Web Local Yield
  - Web Local Crippling
  - Web Compression Buckling
- **Column**
  - HSS Wall Local Yield
  - HSS Wall Local Crippling

## Design Assumptions

VACONNECT makes the following design assumptions for Beam Over HSS connections based on AISC Design Guide 24 and AISC Manual provisions:

- The Beam Over HSS connection is based on the AISC Design Guide 24 the scope of which is restricted to nonseismic applications.
- The out-of-plane motion at the top of the HSS must be restrained by adding a stiffener to the web or by another method. See the AISC Manual Part 2 for additional information and details for beams framing

continuously over columns.

- Bolts of diameter not greater than 1.5 in. must be used.
- The gauge of the bolts must not exceed the beam's flange width.
- The bolt gauge must satisfy the minimum spacing requirements of ACI 360-22 Section J3.4.
- The minimum edge bolt distance for the cap plate and the beam flange must satisfy the ACI 360-22 Table J3.4 requirements.

## Limitations

- Permitted beam and column shapes: W-shapes beams and HSS columns
- Beam is perpendicular to the support column
- Only standard bolt holes are supported
- Only forces in the plane of the connection (axial load and moment) can be checked
- A single beam is framing into the support column
- When an unrecognized beam is imported from VisualAnalysis, the beam's T dimension is assumed to be the depth minus twice the flange thickness (i.e. the fillets are neglected)
- Only fillet welds are allowed at the HSS to cap plate connection (complete-joint-penetration groove and partial-joint-penetration groove weld are not supported)
- The bolt gauge is not checked against the beam's workable gauge
- Bolt entering and tightening clearances are not checked

## 1.19 Wood Bolted Shear Design

A Wood Bolted Shear connection consists of a Main Member and a Side Member connected to one another using one or more steel bolts. The Main Member is a single, solid wood member, while the Side Member can be defined as a single or double member, causing the bolts to be loaded in single or double shear, respectively. The Side Member(s) can be defined using either wood or steel material. VAConnect allows the Side Member(s) to be oriented at any angle relative to the Main Member when a single fastener is used. When multiple fasteners are used, the Side Member(s) must be parallel or perpendicular to the Main Member.

### Design Considerations

Wood Bolted Shear connections are checked per the American Wood Council, National Design Specification for Wood Construction, 2018 edition (NDS).

### Connection Yield Modes

Four primary connection yield modes are specified for dowel-type fasteners, which are used to determine the reference lateral design value,  $Z$ , for a single fastener.

**Mode Im & Is** - Bearing-dominated yield of wood fibers in contact with the fastener in either the Main or Side Member(s), respectively.

**Mode II** - Pivoting of the fastener at the shear plane with localized crushing of the wood fibers near the faces of the wood member(s).

**Mode III<sub>m</sub> & III<sub>s</sub>** - Fastener yield in bending at one plastic hinge point per shear plane, and bearing dominated yield of the wood fibers in contact with the fastener in either the Main or Side Member(s), respectively.

**Mode IV** - Fastener yield in bending at two plastic hinge points per shear plane, and localized crushing of wood fibers near the shear plane(s).

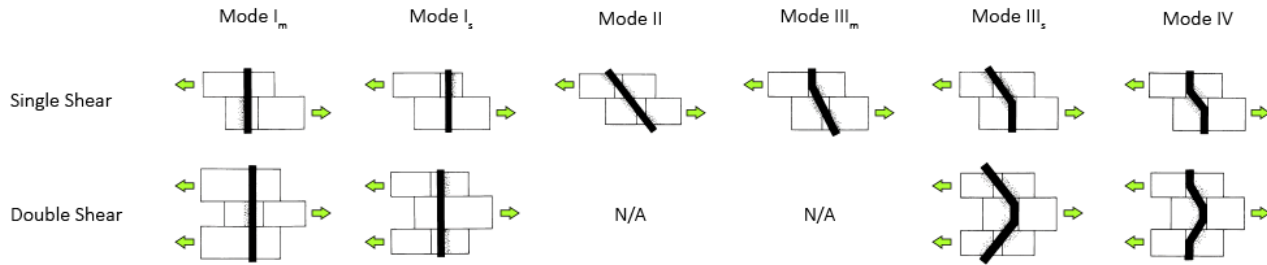

## Adjustment Factors

The Adjusted Lateral Design Value ( $Z'$ ) is determined by calculating the appropriate Adjustment Factors (C-factors), as shown below.

$$Z' = Z \times CD \times CM \times Ct \times Cg \times C\Delta \times Ceg \times Cdi \times Ctn$$

where:

- CD, Load Duration Factor - NDS Section 11.3.2
- CM, Wet Service Factor - NDS Section 11.3.3
- Ct, Temperature Factor - NDS Section 11.3.4
- Cg, Group Action Factor - NDS Section 11.3.6
- C $\Delta$ , Geometry Factor - NDS Section 12.5.1
- Ceg, End Grain Factor - NDS Section 12.5.2
- Cdi, Diaphragm Factor - NDS Section 12.5.3
- Ctn, Toe-Nail Factor - NDS Section 12.5.4

The Adjustment Factor Reports show details of how each factor is calculated, with the exception of the End Grain, Diaphragm, and Toe-Nail Factors, which are not calculated directly by VACONNECT, but can be overridden. Individual Adjustment Factors can be ignored ( $C = 1.0$ ) or overridden using the Project Settings.

## Connection Loading for Adjustment Factors

In VACONNECT, Axial and/or Shear loads are applied to the Side Member. A resultant load is calculated from the axial and shear components and applied to the bolt group. VACONNECT uses the resultant load and the orientation of the member under consideration to determine if the load is parallel or perpendicular to the member grain. **The resulting load direction, parallel or perpendicular to the member grain, is used when calculating the Geometry Factor (C $\Delta$ ) and the Group Action Factor (Cg).**

As shown in the Figure below, loading is assumed to be Parallel to the Grain when the direction of the resultant load is within 45-degrees of the member's centerline orientation. Conversely, when the loading is outside of this range, the loading is assumed to be Perpendicular to the Grain.

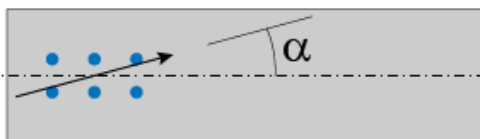

When the resultant load is oriented  $-45^\circ \leq \alpha \leq 45^\circ$  to the member, loading is assumed to be *Parallel to the Grain*. Otherwise, loading is assumed to be *Perpendicular to the Grain*.

For Parallel to Grain loading, definitions for the End Distance (tension and compression), Edge Distance, and Spacing (between bolts and between rows) values are shown in the Figure below. Note: For the bolt group shown, there are two Rows of Bolts, with each row having three Bolts Per Row.



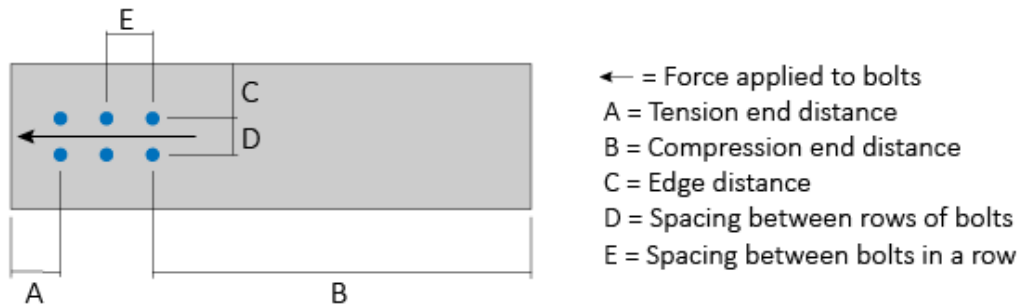

For Perpendicular to Grain loading, definitions for the Loaded/Unloaded Edge Distance, End Distance, and Spacing (between bolts and between rows) values are shown in the Figure below. Note: For the bolt group shown, there are three *Rows of Bolts*, with each row having two *Bolts Per Row*.

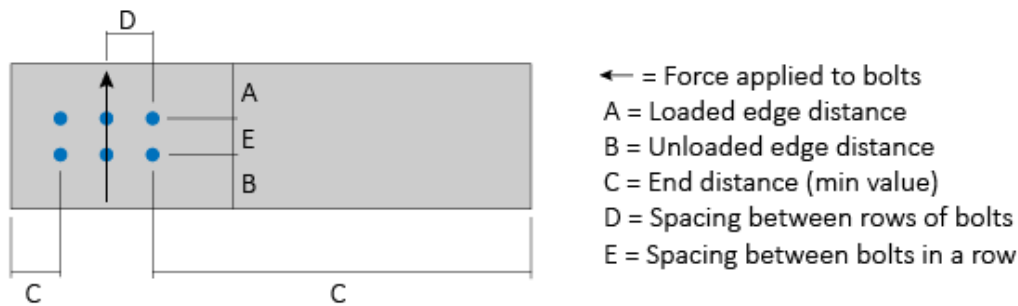

## Local Stresses in Fastener Groups

When a wood member is loaded parallel to the grain, the capacity of a group of bolts may be limited by wood failure at the net section or tear-out around the bolt group caused by local stresses. VAConnect checks the Net Section Tension Capacity, Row Tear-Out Capacity, and Group Tear-Out Capacity for both the Main and Side Member(s) according to NDS Appendix E. The Group Tear-Out limit state considers three tear-out groups, as shown in the Figure below.



The local stress limit states are based only on the tension component of the resultant load for the member being considered. In

# VAConnect 7 User's Guide

other words, the design load is determined as the component of the resultant load that aligns with the member's centerline. The influence of shear on the Net Section Tension Capacity, Row Tear-Out Capacity, and Group Tear-Out Capacity is not considered by VAConnect.

## Limit States

VAConnect checks the following limit states for Wood Bolted Shear connections (refer to the program's detailed reports for specific code references):

- **Connection Yield Modes**
  - Mode I - Main Member and Side Member(s)
  - Mode II
  - Mode III - Main Member and Side Member(s)
  - Mode IV
- **Local Stresses in Fastener Groups - Main and Side Members(s)**
  - Net Section Tension
  - Single Row Tear-Out
  - Fastener Group Tear-Out

## Design Assumptions

VAConnect makes the following design assumptions for Wood Bolted Shear connections:

- Members must be in contact at the shear planes (i.e. no gaps between members).
- Members cross sections must be solid material.
- The bolt hole size is assumed to be the bolt diameter + 1/16-inch.
- A standard cut washer is assumed to be provided between the wood and the bolt head and between the wood and the nut.
- The dowel bearing strength,  $F_e$ , for steel members is calculated as  $2.4 * F_u / 1.6$  (see NDS Appendix I, Section I.2).
- When checking the limit states of Net Section Tension, Row Tear-Out, and Group Tear-Out, only the tension component of the load is considered. The influence of shear on these limit states is not considered.
- Member loading orientation, Parallel or Perpendicular to the Grain, is determined based on the relationship of the resultant load and member orientation, as described in the [Connection Loading](#) section above, and used when calculating the Geometry Factor ( $C_{\Delta}$ ) and the Group Action Factor ( $C_g$ ).
- When calculating the Geometry Factor ( $C_{\Delta}$ ), the End Distance Requirement of Table 12.5.1A for Parallel to Grain, Tension Loading assumes softwood materials for the Main Member and Side Member(s) when a wood material is specified.
- When calculating the Group Action Factor ( $C_g$ ), a *Row of Fasteners* is assumed to be two or more bolts that are aligned with the direction of loading, using the [Connection Loading](#) assumption previously discussed. As shown in the image below, when the resultant load is within 45-degrees from the X-Axis (horizontal), an individual bolt group row will be considered as a *Row of Fasteners*. Conversely, when the resultant load is within 45-degrees from the Y-Axis (vertical), an individual bolt group column will be considered as a *Row of Fasteners*.



← = Resultant Load within 45-deg of horizontal  
[ ] = Row of Fasteners

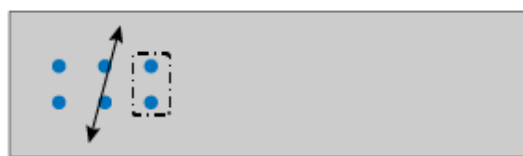

← = Resultant Load within 45-deg of vertical  
[ ] = Row of Fasteners

## Limitations

- The Main Member material must be wood.

- The Side Member(s) material can be either wood or steel.
- The minimum bolt diameter is 0.25-inch.
- The maximum bolt diameter is 1-inch.
- When multiple bolts are present, the Side Member orientation must be either parallel or perpendicular to the Main Member.
- The Geometry Adjustment Factor ( $CD$ ) is only calculated for wood members. The user is responsible for checking bolt hole, bolt spacing, and edge distance limits in steel Side Member(s).
- The End Grain Factor ( $Ceg$ ), Diaphragm Factor ( $Cdi$ ), and Toe-Nail Factor ( $Ctn$ ) are not calculated directly. These factors can be ignored ( $C = 1.0$ ) or overridden with a custom value.

## 1.20 Wood Fastener Withdrawal Design

A Wood Fastener Withdrawal connection consists of a Main Member and a Side Member connected to one another using a single dowel-type fastener. The Main Member is a solid wood member, while the Side Member can be defined using either wood or steel material.

### Design Considerations

Fastener Withdrawal connections are checked per the American Wood Council, National Design Specification for Wood Construction, 2018 edition (NDS). VAConnect checks the following limit states for Wood Fastener Withdrawal connections (refer to the program's detailed reports for specific code references):

- Fastener Withdrawal
- Fastener Head Pull-Through

The Adjustment Factor Reports show details of how each factor is calculated. Individual Adjustment Factors can be ignored ( $C = 1.0$ ) or overridden using the Project Settings.

### Fastener Types

VAConnect considers the following fastener types.

- Lag Screws
- Wood Screws
- Nails - Smooth Carbon
- Nails - Smooth Stainless Steel
- Nails - Roof Sheathing Ring Shank
- Nails - Post Frame Ring Shank

### Withdrawal

The Adjusted Withdrawal Design Value ( $W'$ ) is determined using NDS Section 12.2 and the appropriate Adjustment Factors (C-factors), as shown below.

$$W' = W \times CD \times CM \times Ct \times Ceg \times Ctn$$

where:

$CD$ , Load Duration Factor - NDS Section 11.3.2

$CM$ , Wet Service Factor - NDS Section 11.3.3

$Ct$ , Temperature Factor - NDS Section 11.3.4

$Ceg$ , End Grain Factor - NDS Section 12.2, 12.5.2

Ctn, Toe-Nail Factor - NDS Section 12.5.4.1

## Head Pull-Through

For models with a wood Side Member and round head fasteners (not Lag Screws), pull-through of the fastener head from the Side Member is considered using NDS Section 12.2.5. The Adjusted Reference Pull-Through Design Value ( $WH'$ ) is determined by calculating the appropriate Adjustment Factors (C-factors), as shown below.

$$WH' = WH \times CD \times CM \times Ct$$

where:

CD, Load Duration Factor - NDS Section 11.3.2

CM, Wet Service Factor - NDS Section 11.3.3

Ct, Temperature Factor - NDS Section 11.3.4

## Design Assumptions

VAConnect makes the following design assumptions for Wood Fastener Withdrawal connections:

- Members must be in contact (i.e. no gaps).
- Members cross sections must be solid material.
- The fastener diameter and main member specific gravity must be within the ranges given in NDS Tables 12.2A through 12.2E.
- The fastener head diameter and side member thickness must be within the range given in NDS Table 12.2F for the Pull-Through limit state.
- The head pull-through limit state is not checked for Lag Screw fasteners since they do not have round heads.
- Installation requirements outlined in NDS Section 12.1 and 12.2 are assumed to be met.
- When the fastener is inserted in the side grain of the member, the axis is assumed to be perpendicular to the wood fibers.
- When the fastener is inserted in the end grain of the member, the axis is assumed to be parallel to the wood fibers.

## Limitations

- The Main Member material must be wood.
- The Side Member material can be either wood or steel.
- The tensile strength of Lag Screw (NDS 12.2.1.4) and Wood Screw (NDS 12.2.2.5) fasteners at the net section shall not be exceeded when loaded in withdrawal. This requires additional consideration by the designer.
- The fastener length must be at least 2x the diameter.

## 1.21 Reporting

In VAConnect, reports are easily created to document the connection design. Switch to the **Report View** tab and select from the available detailed reports or tables in the **Project Manager | Modify** tab to include in the report. The Design Summary report displays an image of the model with some input data and each limit state conveniently summarized in one table. The Detailed (hand calculation style) reports show intermediate calculations for every limit state. The Table reports summarize each limit state with a row for each design load. Load keys are used to identify each design load and its corresponding result. Load keys uniquely identify the paired load set and load combination that created the ultimate strength design load.

## 1.22 Support Resources

### Did you Search this Help File?

Take advantage of the help and support built into the software, as described in the [Program Layout](#) section of the User's Guide. This document can be searched, and you should try different potential terms, sometimes less is more when searching (use just the unique word or words). A Table of Contents is also available.

### Do Not Contact Support For:

- **Licensing/Sales.** Use [www.iesweb.com](http://www.iesweb.com) or [sales@iesweb.com](mailto:sales@iesweb.com).
- **Modeling Advice.** Determining how to model a structure is your responsibility as an engineer.
- **Model Validation.** IES cannot validate your model or your results. If you can document a software defect, contact support and we will investigate further and create fixes as necessary.
- **Engineering Theory.** IES is not in the business of educating engineers. There are textbooks referenced in this help file.

### Technical Support

- **Support Email:** [support@iesweb.com](mailto:support@iesweb.com). Replies are usually within 2 business hours, if you don't hear anything within a business day, assume it got spam filtered or lost and follow-up. For best results, be sure to ask a question, indicate exactly which IES product & version you are using, include as much detail as is practical. If relevant, please attach a project file and/or screenshots.
- **Support Telephone:** Not Available. We have found this to be too inefficient for everybody. With email you can attach a screen shot, a project file, and we can better direct your question to the IES expert for that product or area. Phone tag takes longer than you think.
- **Business Questions:** For any licensing or sales-related questions or issues contact [sales@iesweb.com](mailto:sales@iesweb.com).

## 1.23 References

1. Fisher, James M., Ph.D., P.E. and Kloiber, Lawrence A., P.E. **Design Guide 1: Base Plate and Anchor Rod Design**. Second Edition. Chicago, IL: American Institute of Steel Construction, 2006. Print
2. ACI Committee 318. **Building Code Requirements for Structural Concrete (ACI 318-22) and Commentary**. Farmington Hills, MI: American Concrete Institute, 2019. Print
3. AISC Committee on Specifications. **Steel Construction Manual**. Sixteenth Edition. Chicago, IL: American Institute of Steel Construction, 2023. Print
4. AISC Committee on Specifications. **Specification for Structural Steel Building (AISC 360-22)**. Chicago, IL: American Institute of Steel Construction, 2022. Print
5. AISC Committee on Specifications. **Design Examples**. Version 16.0. Chicago, IL: American Institute of Steel Construction, 2023. Print
6. American Wood Council. **National Design Specification for Wood Construction (NDS 2018)**. Leesburg, VA: American Wood Council, 2017. Print.
7. American Wood Council. **2015/2018 Structural Wood Design Examples**. Leesburg, VA: American Wood Council, 2019. Print.